

TREE CONSERVATION DURING SITE DEVELOPMENT

by Dr. Kim D. Coder, Professor of Tree Biology & Health Care
Warnell School of Forestry & Natural Resources, University of Georgia
November 2010

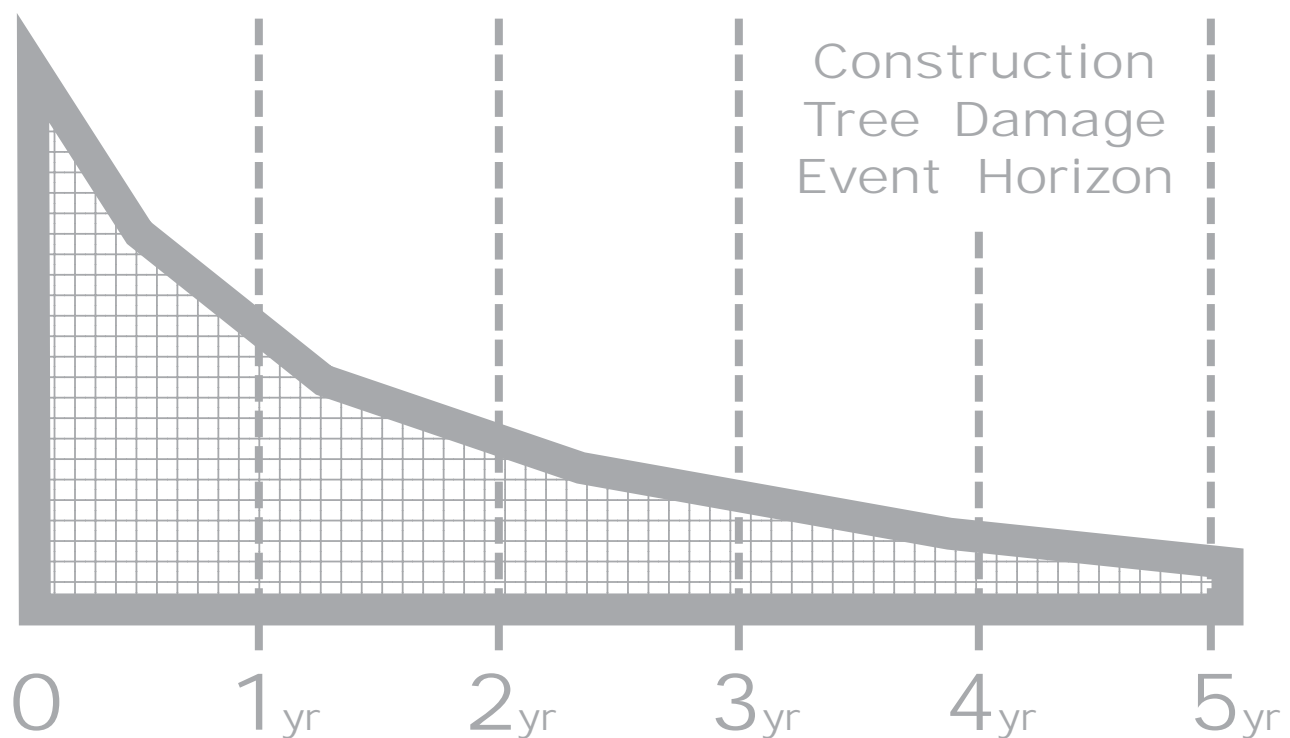

**OUTREACH
MONOGRAPH
WSFNR10-24**



In compliance with federal law, including the provisions of Title IX of the Education Amendments of 1972, Title VI of the Civil Rights Act of 1964, Sections 503 and 504 of the Rehabilitation Act of 1973, and the Americans with Disabilities Act of 1990, the University of Georgia does not discriminate on the basis of race, sex, religion, color, national or ethnic origin, age, disability, or military service in its administration of educational policies, programs, or activities; its admissions policies; scholarship and loan programs; athletic or other University-administered programs; or employment. In addition, the University does not discriminate on the basis of sexual orientation consistent with the University non-discrimination policy. Inquiries or complaints should be directed to the director of the Equal Opportunity Office, Peabody Hall, 290 South Jackson Street, University of Georgia, Athens, GA 30602.

Tree Conservation During Site Development

by Dr. Kim D. Coder, Professor of Tree Biology,
Warnell School of Forestry & Natural Resources, University of Georgia

Trees are valuable to sites where people live, work, shop, and recreate. Tree-generated values impact psychological, social, ecological, and biological aspects of daily life. Planting, cultivation, and conservation of trees on sites where land-use or structural changes occur are important to people.

Modifying the human environment through building, renovating, or removal of physical structures or landscape features is a part of development. Significant changes in a tree's soil, water, energy and biological resources can occur in this process. Understanding site and tree constraints, and the various forms of problems on sites, can help preserve tree values.

Tree quality concerns can be grouped into three distinct time periods:

- A) pre-development planning and site evaluation -- Pre-development concerns revolve around site selection, project planning, and tree and forest attributes;
- B) construction activities -- Construction concerns concentrate on site-layout, tree protection zones and site-damage control; and,
- C) post-development mitigation and monitoring -- Post-development concerns concentrate on restoration of tree functions and values.

Within each time period, are a number of site conservation issues which affect tree and soil quality. Each issue can have a number of assessment processes which can be used to better control development activities around trees and soils. Development site assessments are provided in Appendix #1.

COMPONENT #1: Tree-Literate Design

Tree quality management around development sites must begin early in the planning stage as part of a site-team effort. Tree and site attributes, and their relationship with the design process and construction methods, determine post-development survival, continued tree success, and any requirement for therapeutic treatments.

The first step in tree management is getting tree-literate professionals involved in the planning process. There are times when biological components of a design process may be ignored or given low priority. This action leads to poor tree quality and diminished value production. A tree health care provider must be involved with all the concepts within site development and planning in order to accentuate, or at least maintain, tree values.

Protection of tree and site quality are key aspects in developing a site. To assure whole tree quality, all tree parts must be protected from acute and chronic damage while short and long-term resource degradation is minimized. Tree quality must be interwoven early in the design process, and continually with construction methodologies. Tree quality must be a part of client perceptions and expectations, and translate clearly into planning and design activities. Tree health care professionals must be part of site planning!

COMPONENT #2: Pre-Development Site Evaluation

Systematic site and tree evaluation are essential for maintaining tree values and managing risks on construction sites. There are many great assessment tools for use in both the office with computer generated plans, and in the field covering both pre-, during, and post-construction. These assessments are key to minimizing tree and soil damage and for maintaining project-to-project and site-to-site management success memory.

Begin a pre-development evaluation process at least one growing season in advance of site development activities, if possible. There are many tree and site features to examine -- some of the more important are discussed below.

Numbers. How many trees are present on-site affects many aspects of development. As a rule, the more trees on a site, the more a forest-like atmosphere is generated (up to a point). Over-abundance can be a problem. Sites with too many trees can be as limiting and unresponsive to development as sites with too few trees. Building in dense, overstocked stands can result in decline and death of many trees. Remaining trees are prone to windthrow, pest, storm and ice damage.

The biological occupancy level of trees on a site can be easily determined. Any site, depending upon its inherent productivity, can only hold a given amount of leaf surface area. This leaf surface area can be concentrated onto a few large trees or onto many small trees. Figure 1. For example, 600 five-inch trees, 150 ten-inch trees, 65 fifteen-inch trees, or 40 twenty-inch trees all carry similar total crown volumes per acre. There is a trade-off between the numbers of trees and their sizes for similar site occupancy.

Basal Area. One way to estimate site occupancy or tree density is by measuring basal area (BA). Basal area is a forestry measure that determines the cross-sectional area (in square feet) of all the trees on an acre at 4 ½ feet above the ground (called DBH). This measure can be easily estimated using an angle gauge or prism (or a US 5 cent coin) at a number of random points in an area. Basal area is a direct estimation of crown area or site occupancy.

Using basal area can help quickly establish site occupancy, and expectations of how a site will respond to development. A wooded site would be considered overstocked and unresponsive if basal areas are greater than 70 square feet per acre. A wooded site is under-stocked if basal areas are less than 35 square feet per acre. Tree parks or savannah sites would carry 21-40 square feet of basal area.

Species. Another site feature to examine is the tree species mix. There are many types of trees and associated reactions to site changes. Some will respond well to nearby construction and associated environmental changes -- others will begin to decline almost immediately. Tree species tolerance to site development activities can be found in an associated publication.

The greater variety of trees on a site, the better the chances for long-term health of all trees. A mix of several different species can insure a healthy diversity of tree cover. Work for at least three species per crown class. If a site has only one species, such as only pine, only hickory, or only cottonwood, the site is at risk for tree problems. Invest in, and manage toward, genetic diversity.

Size. A diversity of tree sizes is also important. There should be a mix of small, medium, and large trees. As a general perception rule for a wooded look and feel to a site, for every existing large tree (11 inches diameter or greater), there should be five medium sized trees. For every medium sized tree (5-10 inches diameter), there should be five small trees. For every small tree (1-4 inches diameter) there should be ten seedlings / saplings. Figure 2.

Figure 1: All sites receive the same amount of sunlight energy per acre to power all the trees. Managers can divide this energy into a few big trees or many small trees. The leaf area at full stocking will always be the same.

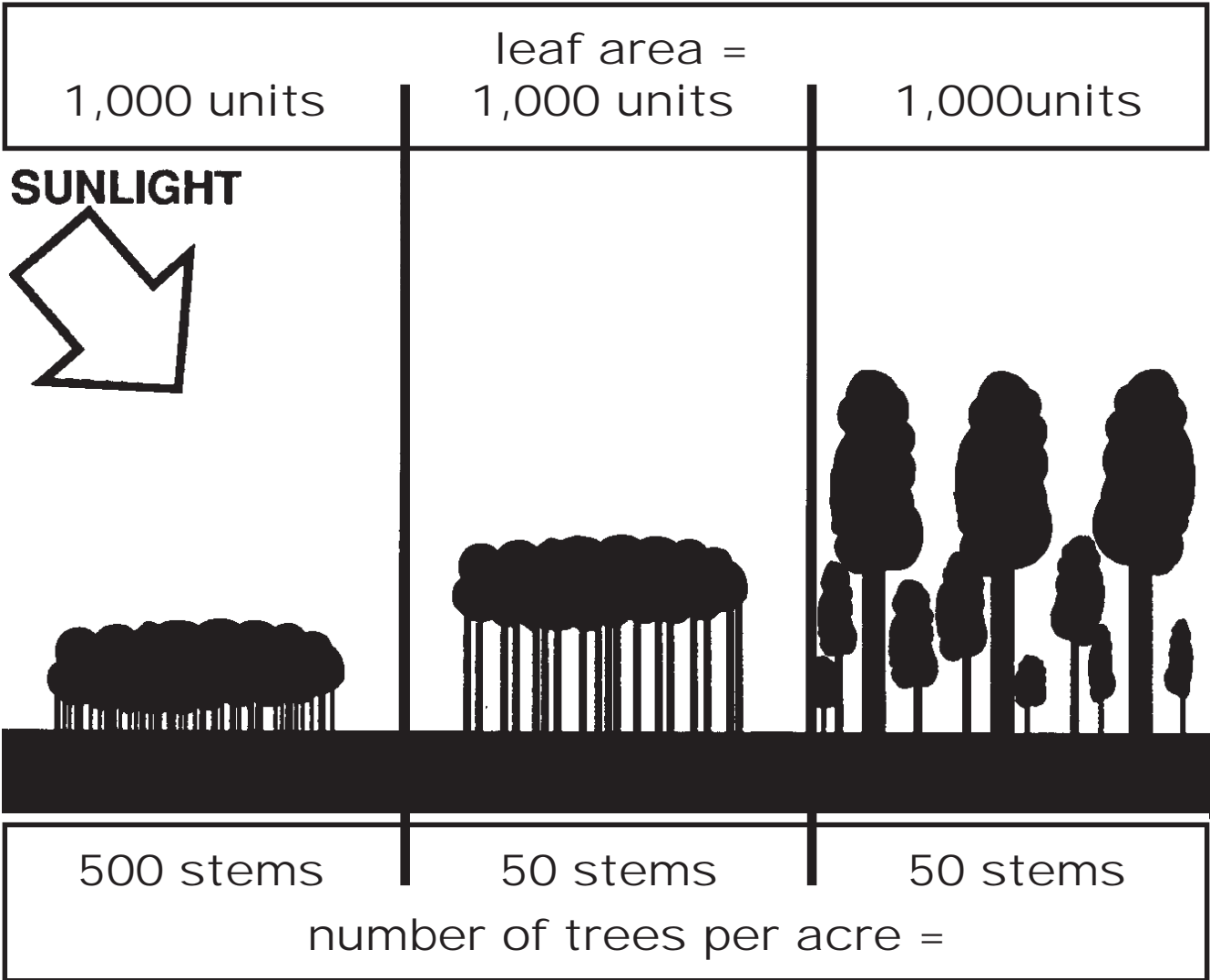
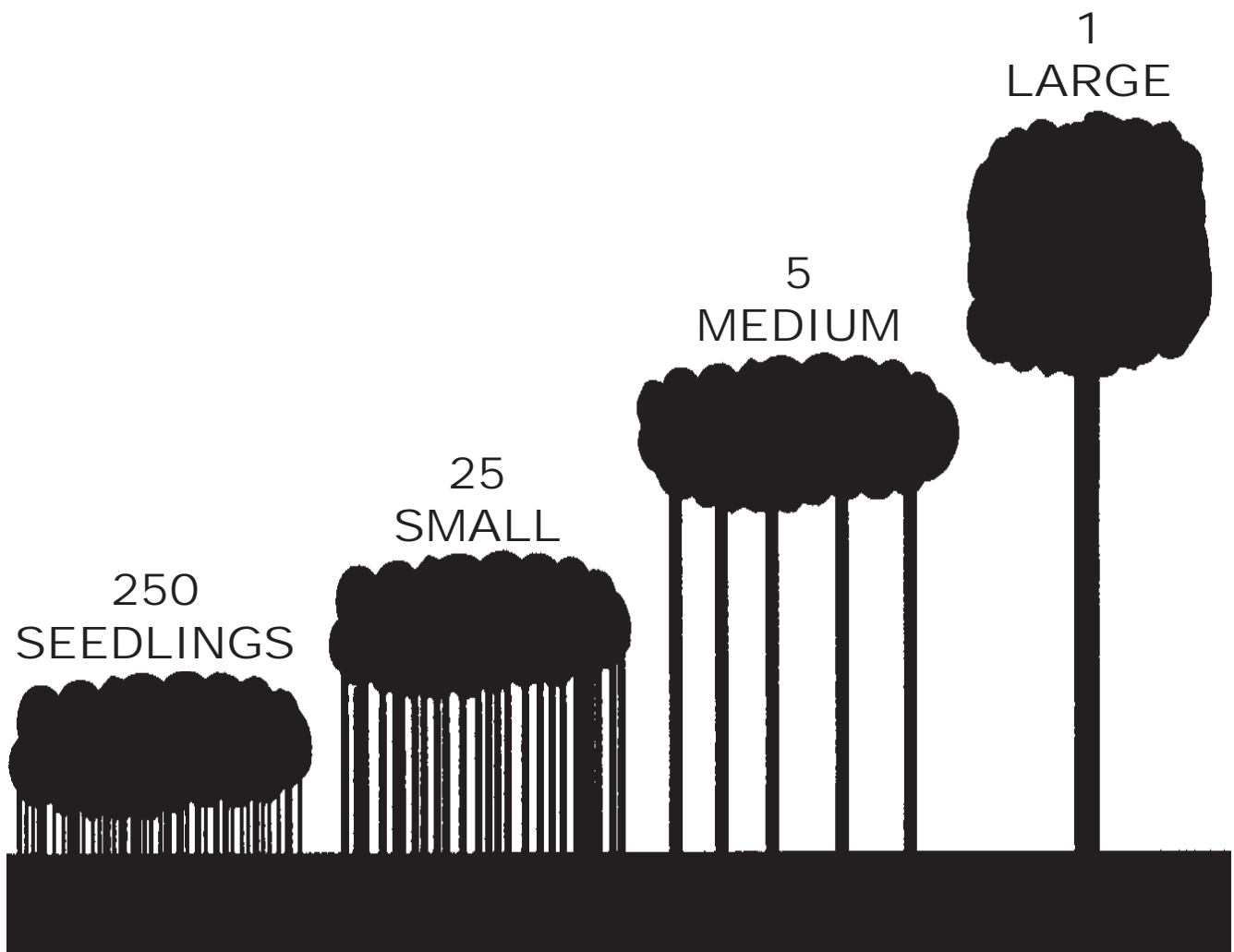

Figure 2: An ideal size distribution for a wooded appearance on a development site.



Crowns. Another valuable evaluation technique is examining tree crowns as an estimate of a tree's potential response to change. Mature trees with a large volume of living crown can react most favorably to development. The proportion of living branches or living crown should ideally comprise 66% of mature tree height. Most trees should at least carry a minimum 35% live crown. If the live crown is less than 20% of total height, problems may develop after construction. Small crowned trees (<10% live crown) would be candidates for removal before construction begins. Figure 3.

Old Damage. Past damage on a site must be recognized and mitigated, or worked around. Site and tree damage may have resulted from past construction, logging, storm, erosion, or land clearing. It is difficult to use machinery between and around trees without damaging tree parts or site resources. Such injuries lead to decline, decay, pests, susceptibility to additional damage, and structural problems. Severe mechanical damage will make it more difficult for trees to adjust to any site changes.

Carefully examine the bottom 20 feet on tree trunks and the basal 10 feet of root area for any scrapings, tears, or wounds. If mechanical injury disrupts more than 1/3 of the trunk's circumference, removal is warranted. The basal portion of the tree withstands the most concentrated structural loads and are most prone to debilitating damage. Survival for trees with severe damage in this basal portion is usually poor over the long-run. Risk assessments should be completed and hazardous trees removed before construction begins.

Soil Problems. The soil surface mirrors past site abuse and current health. The soil surface can show soil disruption, heavy equipment use, and compaction. Soil movement across the surface from natural processes or from equipment can lead to tree damage and site productivity losses. Removing soil can severely damage roots. Excessive fill (defined primarily by soil texture and bulk density) around existing trees can suffocate roots and cause tree decline or death.

Erosion from past and present activities can destroy site productivity and tree quality. The presence of many exposed surface roots and lack of natural litter suggest excessive erosion, compaction, and/or drainage problems. Establishing tree protection areas well before construction begins is critical. Physically protect roots and rooting areas with mulch, fences, plywood sheets, and other physical barriers.

COMPONENT #3: Pre-Development Treatments

After pre-development site and tree evaluations have been completed, treatments can be recommended to minimize potential damage and maximize positive tree reactions to change. Preferably one full growing season in advance of any development activity on the site, and if warranted by tree and site characteristics, treatments could include:

- mark utility and equipment access corridors and assure needed vehicle clearances;
- mark construction danger zones and tree protection zones;
- prune, clean, deadwood, and clear trees;
- mulch tree protection areas;
- set-up tree protection barriers;
- establish irrigation needs and methods;
- fertilize with any essential element showing deficiency in tissue samples except for nitrogen; and,
- make low concentration / slow release / low yield nitrogen applications.

Figure 3: Demonstration of how live crown is measured in a tree. The base of the living crown is determined from where the first main branches grow from the stem, and does not include consideration of incidental sprouts.

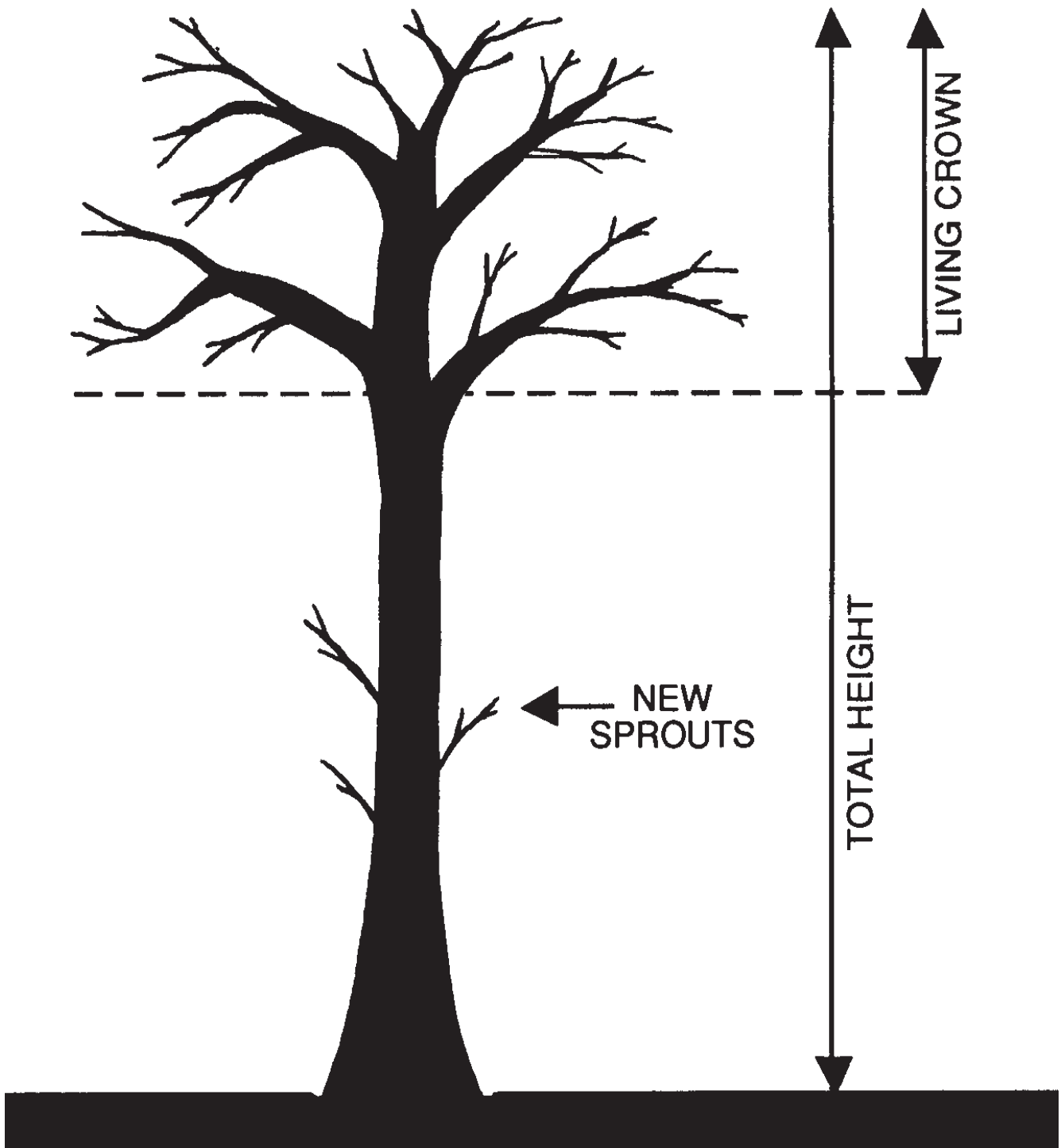

As you are aware, seldom are tree health care professionals allowed the luxury of timely advanced access to sites for evaluations or treatments. Usually tree health care providers are called to fix tree quality concerns after site development activities have commenced and some construction damage has already occurred.

COMPONENT #4: Managing Construction Impacts

The first and most critical rule in working with tree quality on development sites is to “get there first!” The first approach to a tree and over its soils can be the most damaging and facilitate further damage. Tree quality managers need to be the first people to approach all the trees on a site and make removal, treatment, and preservation decisions.

Locate Trees! Tree quality managers need to insure that every person on a site knows where the trees actually are -- not some general circle on a site plan. Plans should include accurate and precise locations for the trunk, crown, and major soil areas colonized by the roots. Remember construction equipment and development activities do not damage tree quality and site resources -- individuals accomplish these actions. Use on-site education, daily monitoring, and/or a strong series of fines, penalties, and rewards to help people remember that trees are important.

Once a site plan is available, determine where tree quality and site resource damage are most likely to be concentrated. When trees are not accurately recorded on site plans, go onto the site and outline on the ground with string where various planned structures and areas will occur.

Define Zones. If a tree is within thirty feet of the string, it is in the “construction danger zone” and should normally be removed to facilitate good construction. Trees within this zone are easily and consistently damaged during construction. These trees decline and die due to damage, or eventually become a hazard to structures and people in the area. Figure 4.

High quality trees between zero and sixty feet from any structure can be individually protected with barriers and stem, branch and root paddings or wraps, if the tree value is warranted. The area between zero and sixty feet from structures is the “tree protection zone.” Trees already in poor condition should be removed. Tree protection barriers should be installed before construction begins anywhere on the site. Barriers will not prevent all damage but will remind people working on the site that trees are important and barriers should be respected.

Provide Space. Protect as much open soil surface as possible below the tree’s crown. Trees require physical space and soil volume to colonize and control. Valuable soil features include:

- physical space for support and pore volume;
- open surface area for oxygen and water movement; and,
- an adequate and sustainable supply of essential soil resources.

To summarize this point, trees with large areas to grow in have the best chance of being healthy, long-lived, and developing few problems. A tree quality manager assists a tree to colonize and effectively utilize a site.

Figure 4: Diagram of a construction danger zone (CDZ) and a tree protection zone (TPZ) around a house foot print. Note two access routes onto the site are not shown.

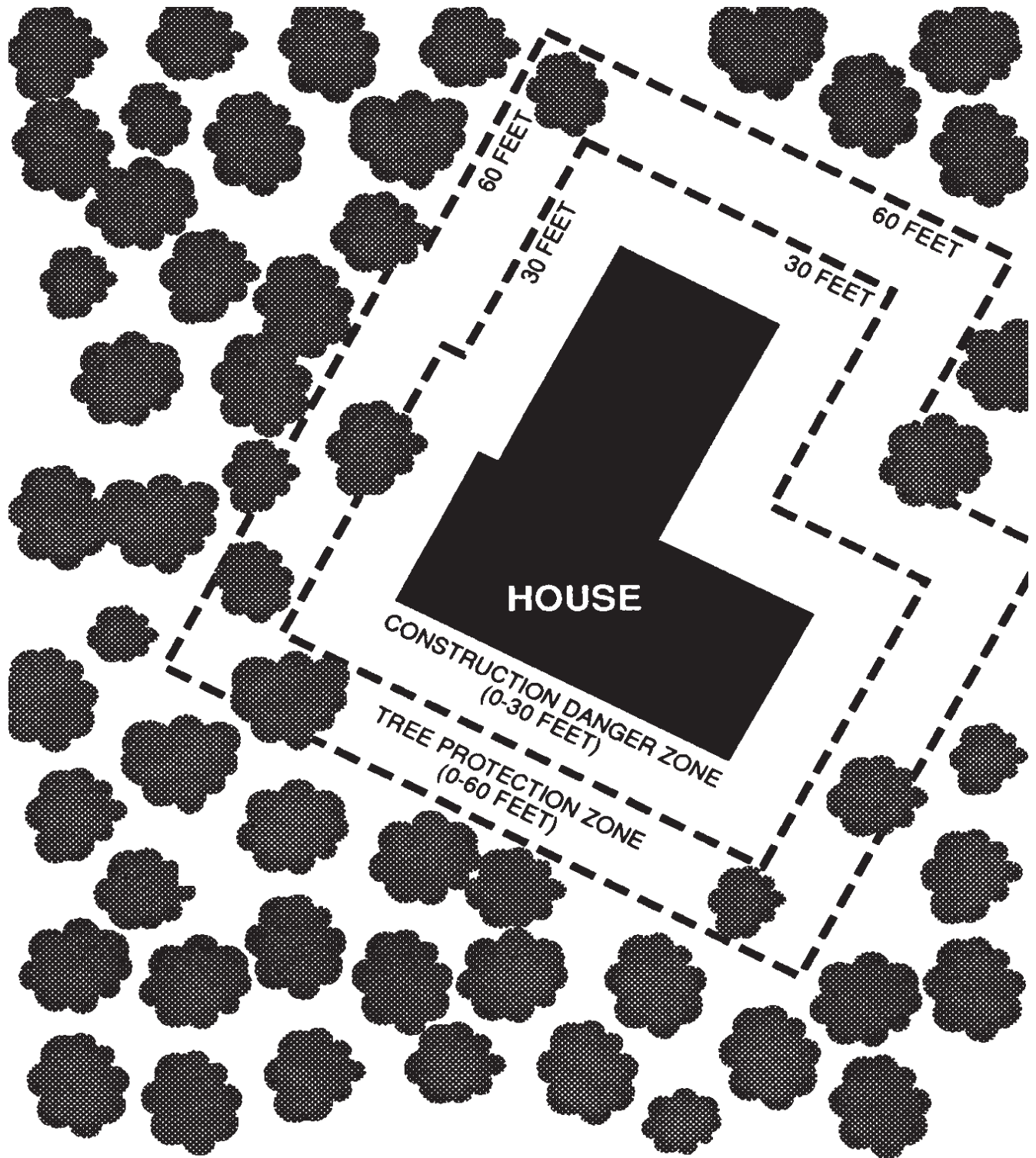

There are a number of ways to determine how much space is minimally needed for tree survival and growth. One effective means of determining a protection distance is using a site-occupancy measure. The expected diameter (DBH) of a tree 10-15 years in the future is estimated. The expected diameter in inches is then multiplied by 2.5 to yield the number of feet in diameter of a tree protection area (critical rooting area). Many times with mature trees, only the current critical rooting area is determined, not providing for any future growth.

Eliminate Potential Problems. Always limit construction machine access, material storage, chemical or cement rinsing, vehicle parking and site-office locations to non-tree areas. Do not let construction equipment near trunks or main rooting areas. Construction activities should not occur beyond 60 feet from site development hardscape, building footprint, or site construction access routes.

Soil level changes over the site can disrupt and destroy roots and negatively modify the soil environment. Fills and cuts, leveling, and surface cultivation or tilling all can damage or kill trees. An often overlooked but critical soil component is water availability and water movement. Soil changes or movement on a site can completely change water flow patterns, ponding, and soil aeration patterns. Soil cuts can drop water tables and available water away from established tree root systems.

Soil Compaction. Construction activities destroy soil resources, functions and values. Soil bulk density or compaction changes can be the most constraining and damaging, while remaining hidden to most site users and planners. Compacted sites do not support vigorous tree growth. Construction sites can easily have 50% greater bulk density than native soils. Increasing bulk density by one-third can be expected to cost a tree one-half of its root and shoot growth.

Soil compaction constrains root growth by acting as a physical barrier to root growth and by blocking oxygen movement to the root surface. Tree roots have difficulty physically penetrating soils with bulk densities greater than 1.7 g/cc, and as the proportion of air pore space (macro-pores) in a soil drops below 15%. Soil compaction is measured as a combination of bulk density of the soil and soil texture. Both components must be known to determine the full extent of tree damaging compaction.

Solutions to compaction problems on development sites include:

- A) deep tillage or sub-soiling (if no tree roots are present);
- B) mulching and composting to reinvigorate soil health (if moisture and aeration are assured);
- C) amending with large, porous, non-compaction solids to create an aerated soil framework;
- D) selective use of porous or open structure surfaces as long as compaction is not used to stabilize the units;
- E) deep core aerators (12-18" depth);
- F) vertical mulching using an auger to drill holes in the soil and backfilling with washed, graded, and non-compaction materials including some soil which leave hole tops open to the atmosphere;
- G) radial trenching away from the tree stem base to 16-24 inches of depth and backfilling with washed, graded, and non-compaction materials including some soil with the trench top left open to the atmosphere; and,
- H) air gun (knife/spade) which stirs soil and does minimal damage to roots.

Items to maintain tree quality through soil management include: prevent and restore high bulk density soils; avoid, treat, and prevent soil contamination by construction materials; and, improve nutrient cycling, moisture balance, and soil structure by top-dressing with organic matter.

Assign Space. Design and control access corridors for utility installation, both underground and overhead. Depending upon local codes for underground utility corridors, two or three trenches are the most needed for all the various utilities. Unfortunately, seldom do various utility providers cooperate in the installation processes to minimize tree quality loss. Utilities lines should be designated to non-tree areas for access, such as along driveways and sidewalks. Working with utility service providers to generate serpentine corridors and tunneling (soil piercing) under tree rooting areas are essential.

Provide room for trucks and construction equipment to get back and forth to the building site. Two access points are needed because large equipment or delivery trucks can not turnaround without extensive site quality losses. An incoming and outgoing access route should be designated for deliveries. This does require a designated, non-tree area for storage of construction materials and parking spaces for construction related vehicles, including laborers and sub-contractors.

BMP Checklist. There are a number of important tree quality conservation items to note and manage as site development activities occur. These include:

- 1) Know the site development and building regulations concerning trees in your area.
- 2) Establish fenced tree protection areas. For trees in harm's way, use tree protection barriers, wraps, and pads, keeping them in good repair.
- 3) Include contractual penalties in real dollars for tree protection area violations and tree barrier damage. Allow dollars to educate reluctant or tree-illiterate people and companies.
- 4) Plan a cement wash-out pit and designate a chemical holding area, both away from tree protection areas.
- 5) Limit site parking and material storage to already damaged areas.
- 6) Allow no site-offices, equipment, or material storage in tree protection areas.
- 7) Keep refueling and maintenance areas away from trees and native soils.
- 8) Control toilet, lunch, break and burn areas, and associated refuse.
- 9) Control and limit on-site soil storage.
- 10) Control and minimize grade changes, and prevent significant water and soil flow / accumulation changes on-site across tree protection areas,.
- 11) Allow only two construction access drives into the site -- one in, one out.
- 12) Control utility over-head and under-ground corridors.
- 13) Be careful of fire dangers to site and surrounding woods during construction and afterwards.

COMPONENT #5: Post-Development Treatments

Post-development tree quality management primarily concerns identification of problems and associated treatments that do not accentuate tree quality losses or further destroy site resources. In addition, sorting out the living trees from the dead, and soon to be dead, is required. Severely damaged trees should be quickly removed and replaced with plantings, if warranted.

Cultural treatments on the post-development site can include:

- weekly water management (the most important item!);
- fertilizing with essential elements shown to be deficient in tree tissue tests;
- wait one growing season for minimal nitrogen applications then maintain minimal levels for 3-5 years;
- if in doubt about the structural integrity or survival of a tree, remove it immediately; and,
- watch closely for pests and changes in tree structure -- preventative treatments may be advisable.

CONCLUSION

The quality of life of a tree and tree owner is dependent upon design and development processes being tree-literate. Tree quality also depends upon timely treatments prescribed which attack the casual agents of problems. Tree quality can be preserved, maintained and restored around development sites if we give trees a biological and ecological chance.

Appendix #1 provides a number of tree and soil assessments for detmining injury potential, resulting damage, and expectations of recovery times.

APPENDIX #1: Site Development Assessment Tools For Trees & Soils

A key component in assessing development impacts on trees is the systematic evaluation of potential damage which may occur, and damage which is already present on a site and its trees. Many forms of damage tends to occur repeatedly over a site, and from site to site. This constant and repetitive damage comes from fundamental anti-tree and tree-illiterate activities. Under scrutiny of a systematic assessment, these patterned damage forms can be prevented or minimized.

Recognizing Good Trees

Some types of damage (one-time, one-spot, chance occurrences) can be assessed but are difficult to prevent. Accidents occur and past history on a site may provide a heiratage of tree problems. By attempting to categorize and catalog potential damage, patterns can be recognized and steps taken to minimize tree injury and site degradation. Please note many development activities and the continued presence of biologically efficient and structurally sound trees are mutually exclusive (spacially and temporally). Decisions must be made early in the planning process to maintain tree quality of life and minimize tree injuries and site damage.

Development Monitors

As development activities occur on a site, continually monitoring damage to tree quality and site resources is essential. Timely communications of potential damaging activities, as well as damage which has occurred is key to tree health and structure. Development of a damage class assessment system will help tune and quantify managerial responses. An assessment process which helps define site problems will help project expected tree life-span changes and losses.

Expected tree reactions to site resource constraints and physical tree damage during site development, and for a number of years after, will vary from: immediate and out-right death; single-year decline and death; multiple-year decline and death; and, decline with major living mass loss. The latter two expectations are the most common among residual trees, and the most ignored and difficult to prove a cause-and-effect relationship coorelated with construction activities.

Head of the Class

One method of assessing site development issues impacting trees is to use a systematic assessment process. This type of assessment generates a set of multiple values suggesting short-term and long-term tree and site quality changes, concetrating on losses. This developement site assessment requires a tree health care provider monitor tree and site changes before, during, and after human activities. Potential damage, and actual damage, can be placed into one or several classes of tree and site problems. This assessment is to help people recognize, catagorize, and manage effective tree responses to site changes.

In order to assess development site issues with trees and soils, and to help place damage into specific classes each of which can be targetted for management intervention, a number of tools are provided. These tools help an assessor more clearly, accurately, and presciously identify and quantify the extent of site and tree damage.

Arriving To Conserve

These damage recognition classes are divided into tree and site compartments where managerial intervention can be targeted. Assessment tools are provided in each class to allow for a more precise and objective means in gauging tree and soil damage. Note no assessment tool can replace an experienced, tree-literate, professionally trained observer. Seek out credentialed tree health care providers for site development planning and for this type of assessment.

The damage classes and associated assessment tools provided here are not a comprehensive collection of perfect infouluable items, but a beginning set of minimal standards or best management practice guides. This assessment process is a beginning designed to help forge awareness and recognition of issues and problems which can over time decrease tree and soil quality and increase liabilities. See Table 1.

Actions Not Regrets

The purpose of tree and site assessment for site development related problems is to stimulate and encourage actions to, at least, help tree health and structure. It is hoped this assessment would help modify how site developemnt activities are planned in the office and executed in the field. Only by changing how people visulize site developement as a tree-affirming and ecologically sustainable process can tree and soil assets losses be minimized.

As each tree and site area are assessed for damage, potential actions should be developed that strive to solve short-term and long-term site problems. These actions should rest in one or more of the following five management catagories:

1. Immediate safety of people and protection of property (safety management);
2. Minimize liability risks developing over time (risk management);
3. Protection of tree and soil assets (tree health and structure management);
4. Managed value appreciation of tree assets (sustainable ecological management);
5. Modification of current goals, objectives, and management plans (reevaluation of management process).

Putting Trees First

Deciding to act on assessment suggestions could include changing project design, modifying construction activities and site management plans, tree removal, tree planting, soil or tree theuropudic treatments, and/or reexamination of site resources and management objectives possible.

Damage assessment forms developed should include individual tree and site reviews, as well as an overall negative impacts to trees and soils which stratifies the work area by intensity of activity and potential damage extent. Assessments can be converted into workorder guides for prescribing immediate treatments. These written assessments also serve as archives records which can assist in diagnosis and amelioration processes in the future.

Assessment Horizon

Included here are a number of tools for helping determine the extent and severity of tree and soil damage. Each must be modified by species, site, circumstances, and management objectives as determined by an experienced assessor. These tools are designed to protect tree quality and minimize damage. As such, they are biologically conservative over a five year time span. Continued tree growth and reactions to change, constant or declining site resources, and disruption of tree reactions and site resources by management activities can compound long-term (>6 years) problems not assessed here. Structural damage and chronic stress problems will remain with a tree for its life.

Table 1: Site development potential damage classes and associated assessment tools for trees and soils.

**Class 1 -- General root system destruction and rooting space loss.
TOOLS #1 - #10.**

**Class 2 -- Root collar and structural support root damage.
TOOLS #11 - #14.**

**Class 3 -- Mechanical / structural damage to stem and branches.
TOOLS #15 - #21.**

**Class 4 -- Soil problems.
TOOLS #22 - #28.**

**Class 5 -- Wind load changes (tree failures under wind loading)
-- Note that this class affects edge or island trees where clearing or thinning has left trees prone to windthrow. This is the only damage class not necessarily a result of direct mechanical or soil damage.
TOOLS #29 - #30.**

**Class 6 -- Instituting obstructions & new microsite attributes -- changes in surroundings that will modify growth success and management activities now and into the future (growing space interference -- new lines, barriers, hardscapes, advected heat, heat loading, buildings, trees).
TOOLS #31 - #32.**

Summary Assessments

**Determining Total Tree Damage Exposure & Recovery Time
TOOLS #33 - #37.**

The final tools are not associated with a damage class but allow the extent of tree and soil damage to be appreciated. The seasonal timing of tree damage does change tree reactions and potential impacts. One of the most important aspects of assessing construction damage to trees is the amount of time development activities occur on a site. Both the absolute time span and the timing of damage in comparison to tree growth patterns are critical to assessing damage and estimating recovery times. Use of a construction damage timing table is both a method of training new assessors and a means of quantifying the potential extent of damage to trees. The last tool is a worksheet for keeping track of major impacts, as determined by damage class. All these assessment tools can help formulate what actions are needed or what actions should be delayed.

List of Assessment Tools for Trees & Soils

CLASS 1 Assessment Tools -- Roots and Space

TOOL #1: Understanding how calculations of rooting area diameter, radius, and soil surface areas around a tree are made.

TOOL #2: Site view from above a tree stem showing the three different rooting areas and their limiting distance away from the tree. Tree rooting areas include: 1) ecological root print area; 2) critical root zone; and, 3) structural root zone (root plate). All limiting distance measures are diameters centered on the tree in feet and calculated from tree diameter (Din) at 4.5 feet above the ground measured in inches. For example -- 20 inch diameter tree (Din = 20 inches), ecological root print distance = 80 feet in diameter; critical root zone distance = 50 feet in diameter; and, structural root zone distance = 18 feet in diameter. The root zone limit distance away from the tree (root distance radius) would be 40 feet for the ecological root print area; 25 feet for the critical root zone area; and, 9 feet for the structural root zone area.

TOOL #3: Estimate the ecological root print area for any tree in the area. This ecological root print distance is based upon root colonization distances away from the tree stem in an unconstrained landscape setting. This is a minimum ecological root print distance away from a tree for encroachment under ideal conditions. For example, a tree with a 20 inch diameter stem (DBH) would have a ecological root print distance of 80 feet in diameter or 40 feet away from the tree stem all the way around (radius). For long term sustainability of the tree and soil health, the ecological root print area should be protected.

TOOL #4: Estimate the critical rooting distance for any tree in the area. This critical rooting distance is based upon the light resources available for each given area of soil, and forestry stocking guides in which 920 square feet of healthy, open soil surface is required per square foot of a tree's cross-sectional area. This is a minimum biological distance away from a tree for encroachment under ideal conditions. For example, a tree with a 20 inch diameter stem (DBH) would have a critical rooting distance of 50 feet in diameter or 25 feet away from the tree stem all the way around (radius).

TOOL #5: Diagram demonstrating acceptable packing density of tree root systems, or the amount of critical rooting area overlap allowed for a tree (A) when surrounded by 2, 3, 4, or 5 other trees with, in these examples, a similar sized rooting area. The percentage given is the maximum overlap of a tree's calculated critical rooting area in percent. Trees directly surrounded by six or more trees should not be allowed any critical rooting area overlap in planning. This packing density percentage is designed to minimize interference impacts of each tree on the others within the soil.

TOOL #6: Allowable joint rooting area percent or overlap of critical rooting areas. Rooting area overlap values per tree are based upon critical rooting area values ($4.91 \times (\text{tree diameter in inches})^2 = \text{critical rooting area in square feet}$). These joint rooting area overlap values should be used where trees share common soil space in linear, island or clump plantings.

TOOL #7: Calculated critical rooting distance radius values in feet for use in minimizing any type of encroachment on essential tree rooting space. Tree critical rooting radial distance given here is the essential root colonization area surrounding a tree for sustaining tree health. The values listed are the minimum distance away from a tree to exclude potential damaging activities. Do not trespass or work closer to the tree trunk than the critical rooting distance listed in feet of radius.

TOOL #8: Percent tree rooting area disrupted when soil and roots are damaged on one side. Damaged root percents are provided by 1/5s along the radius from the stem. If the critical rooting area distance is calculated and then divided into 1/5s, the amount of active roots (in percent) destroyed are given, as damage is located closer to the tree stem base.

TOOL #9: Percent tree rooting area disrupted when soil and roots are damaged all around a tree. Damaged root percents are provided by 1/5s along the radius from the stem. If the critical rooting area distance is calculated and then divided into 1/5s, the amount of active roots (in percent) destroyed are given, as damage is located closer to the tree stem base.

TOOL #10: Percent of critical rooting area disrupted by development activities approaching tree and impacting soil. The whole area impacted is any activity which disrupts rooting surrounding a tree on all sides, like a cut or fill process. Half area impacted is any activity which disrupts rooting surrounding a tree on any side, like trenching.

CLASS 2 Assessment Tools -- Roots Plates and Structure

TOOL #11: Side view of a tree root plate area showing root plate depth and location of its hinge point. The decimal values are the multiplier of tree diameter inches yielding diameter of root plate in feet or radial dimensions in feet: root plate diameter = 0.9; hinge point radius = 0.15; root plate depth = 0.3.

TOOL #12: View from above of a tree root plate surrounding a tree of a set diameter (DBH_{in}). The decimal values are the multiplier of tree diameter inches yielding diameter of root plate in feet or radial dimensions in feet: root plate diameter = 0.9; hinge point (90° to leeward, arc radius A-B) = 0.15.

TOOL #13: Estimate the structural rooting area distance for any tree in the area. This structural rooting area distance limit is based upon biomechanical models of tree root strength and root plate resistance to wind loads. This is a minimum structural distance away from a tree for any type of encroachment under ideal conditions. For example, a 20 inch diameter tree would have a structural rooting area or a root plate of 18 feet in diameter or 9 feet out from the stem on all sides (radius).

TOOL #14: Structural rooting distance in feet of radius, or root plate radius distance, used to minimize damage to tree structural base and minimize catastrophic tree failures due to root damage. The structural rooting area or root plate (i.e. pedestal roots or roots holding the tree erect under compression) should be protected from all disruption. Significant risk of catastrophic tree failure exists if structural roots within this given radius are destroyed or severely damaged.

CLASS 3 Assessment Tools -- Stem & Branch Damage

TOOL #15: Determining the extent and severity of mechanical injuries to trees on development sites.

TOOL #16: Steps in determining the Damage Assessment Value for a tree injury.

TOOL #17: A tree diagram showing areas of a tree where load forces are concentrated and where the tissues around injuries have holding forces concentrated. Score values for different injury locations within critical tree structural zones for use in assessing damage.

TOOL #18: Coder Crown Raising Dose Assessment per pruning cycle for demonstrating potential crown raising abuse around a development site. Graph is the percent of live crown (height basis) that can be removed, if warranted. On many development sites a first tree management step (or tree abuse step) is pruning up the bottom few branches of a tree to gain access, prevent damage to equipment and tree, and provide more storage space. Crown raising in small amounts may be needed and warranted. Too much pruning will lead to tree decline and death.

TOOL #19: Diagram of a tree stem cross-section showing sapwood and heartwood (shaded). Construction damage to major branches is judged after the injuries have been properly cleaned-up and a standard pruning cut is made. Only after the final pruning cut is completed can full branch damage be assessed. Additional damage can occur after the construction pruning injury as a result of improper pruning tools, techniques, and skills. In this assessment it is assumed proper standard pruning practices will be followed. Within standard pruning practices, heartwood and decay column exposure will be used to estimate damage to the health and structure of the tree now, and into the future.

This assessment system provides a user with the maximum number of cuts per wound damage class that should be made without significant damage to a tree. The basis of this system is examination of the cross-section of the living base of any properly pruned branch. It is critical that assessors differentiate between heartwood, sapwood, and chemically altered wood areas (decay, discoloration, and defensive responses) in order to determine the types and number of branch pruning cuts remaining after a tree is cleaned-up from construction injuries. Remember significant damage and liability risks exist on injured trees on development sites now and into the future.

TOOL #20: Coder Heartwood Exposure on Pruning Wounds Assessment for trees pruned, tipped or topped during development. Heartwood exposure is a deep cut into and across tree defensive systems. The more heartwood exposed, regardless of the size and age of a stem or branch, the greater potential damage to a tree.

TOOL #21: Maximum number of pruning wounds applied to a single tree by heartwood exposure wound type on a development site. Exceeding this count magnifies tree damage significantly.

CLASS 4 Assessment Tools -- Soil Health & Strength

TOOL #22: The number of passes over the same square inch of soil to increase bulk density (compact soil) to 95% of what it can be compacted.

TOOL #23: Soil textures classifications based upon sand and clay proportions, and dotted lines showing root-limiting bulk densities (g/cc). Values equal to or greater than the listed density value (to the right of) will significantly constrain tree root growth.

TOOL #24: Soil compaction limitations on tree root growth and survival. Listed are soil physical attributes (soil bulk density in g/cc and soil air pore space percent) by soil texture class, where tree root growth becomes severely limiting. General tree root growth limits include a physical limit on root growth as soil density reaches and exceeds > 1.7 g/cc bulk density, and an aeration pore space limit on root growth when $< 15\%$ aeration pore space remains in a soil.

TOOL #25: Effective soil depth in soils of various textures under compacted and non-compacted conditions. Deep soil under limited aeration, poor drainage, or severe compaction do not allow soil ecological systems (aerobes), including tree roots to function too far below the soil surface. Soil depth provided is not nearly as important as wide-spreading, shallow, open soil surface area around a tree.

TOOL #26: Soil rutting potential on wet soils under development activities. Rutting causes root crushing and severing. Maintenance equipment can seriously damage soil health through driving over the same place over time. Ground pressure (psi) for vehicles: rubber tires = 20+; crawler track = 12+; and, floatation tires = 6+.

TOOL #27: Soil fill or lifts. Approximate amount of soil fill, by texture class, that can be applied before having significant negative impacts on tree root health and growth. These are highly variable values depending upon crusting, compaction, aeration/drainage, native soil attributes, residual structure, application method, organic matter content, and other compounding soil / site problems. All types and quantities of fill can lead to root suffocation and other acute and chronic problems that permanently damage trees. Judging the threshold of potential damage is a professional decision beginning with site management objectives.

TOOL #28: Soil cuts. Approximate amount of soil removal, by texture class, taken away before having significant negative impacts on tree root health and growth. These are highly variable values depending upon compaction, aeration/drainage, native soil attributes, residual structure, removal method, organic matter content, and other compounding soil / site problems. All soil removal can mechanically disrupt root tissue leading to acute and chronic problems that permanently damage a tree. Judging the threshold of potential damage is a professional decision beginning with site management objectives.

CLASS 5 Assessment Tools -- Tree Risks of Failure

TOOL #29: Tree Structural Risk Assessment. This assessment help formulate a potential risk for catastrophic tree failure. A tree is most likely to fail where it is weakest and under the greatest mechanical load. Liability issues arise where people and property are under or near the tree when it could fail. A Risk assessment to determine whether a tree is hazardous is a key part of tree management on a development site.

TOOL #30: Tree Structural Risk Assessment Form. This form lets you record your observations and develop a record for trees at risk of failure.

CLASS 6 Assessment Tools -- Obstructions & Microsites

TOOL #31: Diagram showing how heat loading can be estimated on a site using a combined and averaged view-factor from 10 equal (36°) observation angles. Distances given are based upon an observation height of 5.5 feet.

TOOL #32: Heat load multiplier values for various non-evaporative, dense surface view-factors (nearest 10% class) for a site or tree. Use heat load multiplier to estimate increased water use and carbohydrate use in trees under various heat loads.

Summary Assessment Tools -- Exposure & Recovery

TOOL #33: Calculating tree damage exposure value using a tree growth season counter. One of the most important aspects of assessing site development damage to trees is the amount of time development activities occur on a site. Both the absolute time span and the timing of damage in comparison to tree growth patterns are critical to assessing potential tree damage and estimating recovery times. Use of a construction damage timing table is both a method of training new assessors and a means of quantifying the potential extent of damage to trees.

This assessment process can help drive various scenarios in the planning process to minimize the “Tree Damage Exposure Value.” The Tree Damage Exposure Value is determined by establishing a time-line for beginning and ending construction activities on a site. Components of the Tree Damage Exposure Value include the number of different tree growth seasons construction activities have spanned, which tree growth season construction activities began within, which tree growth season construction activities ended within, and how many full years have been involved in the construction process.

TOOL #34: Tree Damage Exposure Value. The extent and severity of development site damage to trees is in part dependent upon how many individual growth periods to which a tree has been subjected. The principle four tree growing seasons are dormancy (DORM), the first part of the growing season from bud break to when leaves are fully expanded (GS1), the second part of the growing season which ends when approximately 80% of the growing season has been completed or trees are starting to enter fall senescence (GS2), and senescence when trees just begin to generate a leaf color change in fall (first darker green then paler green) until leaves are dead and fall (SENC). These tree growth periods will be used to help estimate duration and severity of development site damage. The components of this assessment are given.

TOOL #35: Calculated tree damage exposure values in a table format. To determine a Tree Damage Exposure Value, begin at the top of the table and identify when construction activities began on the site (by tree growth season). Next move downward in the appropriate starting column until you reach the row representing the end of construction activities on the site. The number presented is the relative “Tree Damage Exposure Value.”

TOOL #36: Tree recovery time determination. Recovery timing is based upon each tree growth period impacted by site development activities (running concurrently). Recovery time commences when construction activities end on a site. Landscape disruption and installation are the final parts of site development and can be extremely damaging, especially to any mature trees present. When the last machinery has left the site and the

landscape and hardscape are completely installed, recovery timing can begin. Recovery timing uses the same time-line and four tree growth periods as the development activities tree damage exposure value calculation. For each tree growth period affected by site development activities, a specific length of recovery should be observed. Because of tree biology, recovery time periods are not additive, but run concurrently as each tree growth season is affected and grown past.

TOOL #37: Site development and construction damage event horizon for trees. Although severe damage can cause an immediate death of a tree, site changes and cumulative injury and stress cycles caused by site development activities can still be the primary cause of tree decline and death a number of years after construction. This figure points out the normal five year damage event horizon for trees after development activities have ended.

TOOL #1: Calculating rooting area diameter, radius, and soil surface area around a tree.

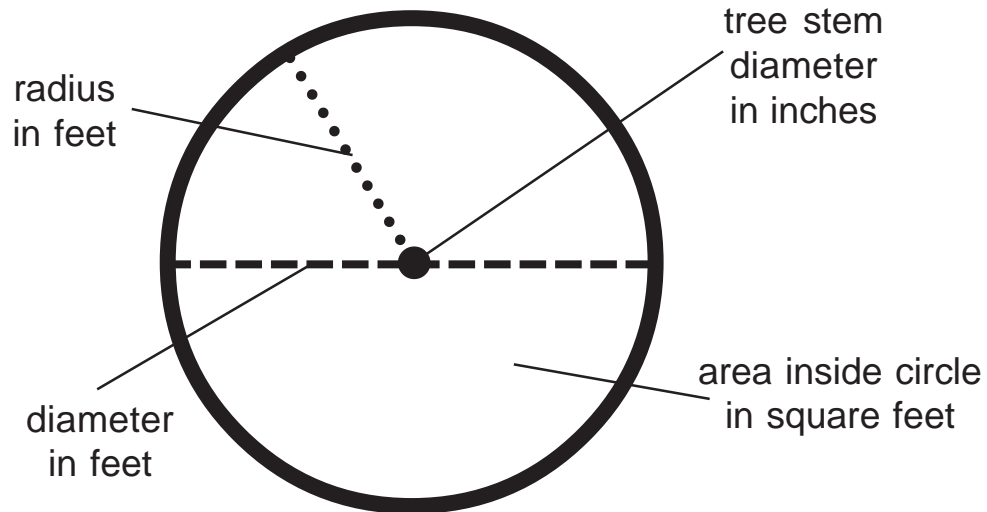

Tree Rooting Distance

(in feet away from or around tree stem)

Diameter of Rooting Distance in feet =
 $2.0 \times \text{Radius of Rooting Distance in feet}$

Radius of Rooting Distance in feet =
 $0.5 \times \text{Diameter of Rooting Distance in feet}$

Tree Rooting Area

(in square feet of soil surface area away from tree stem)

Rooting Area in square feet =
 $0.785 \times (\text{Diameter of Rooting Distance in feet})^2$

Rooting Area in square feet =
 $3.14159 \times (\text{Radius of Rooting Distance in feet})^2$

TOOL #2: Site view from above a tree stem showing the three different rooting areas and their limiting distance away from the tree.

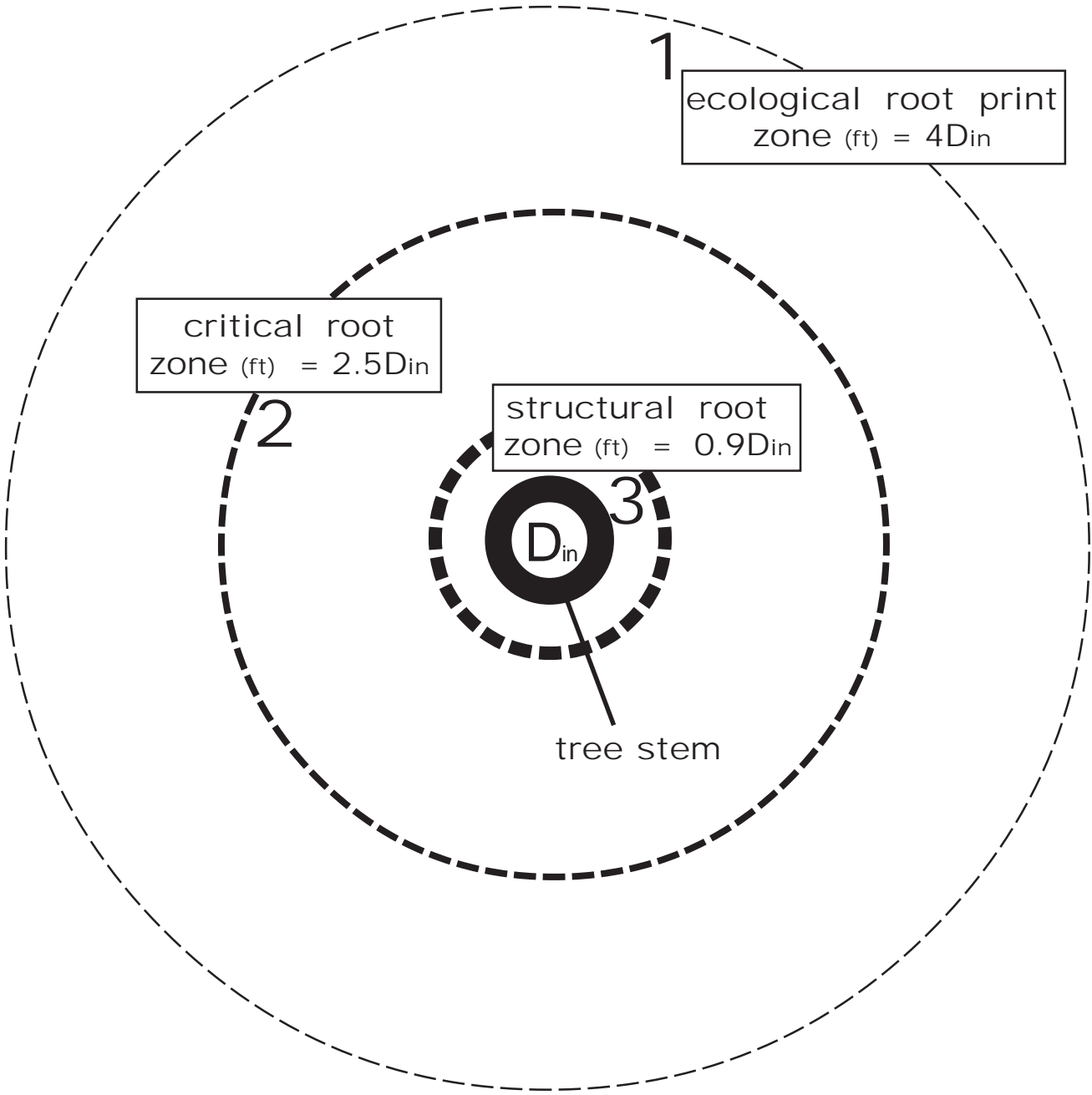

TOOL #3: Estimate the ecological root print area for any tree in the area.

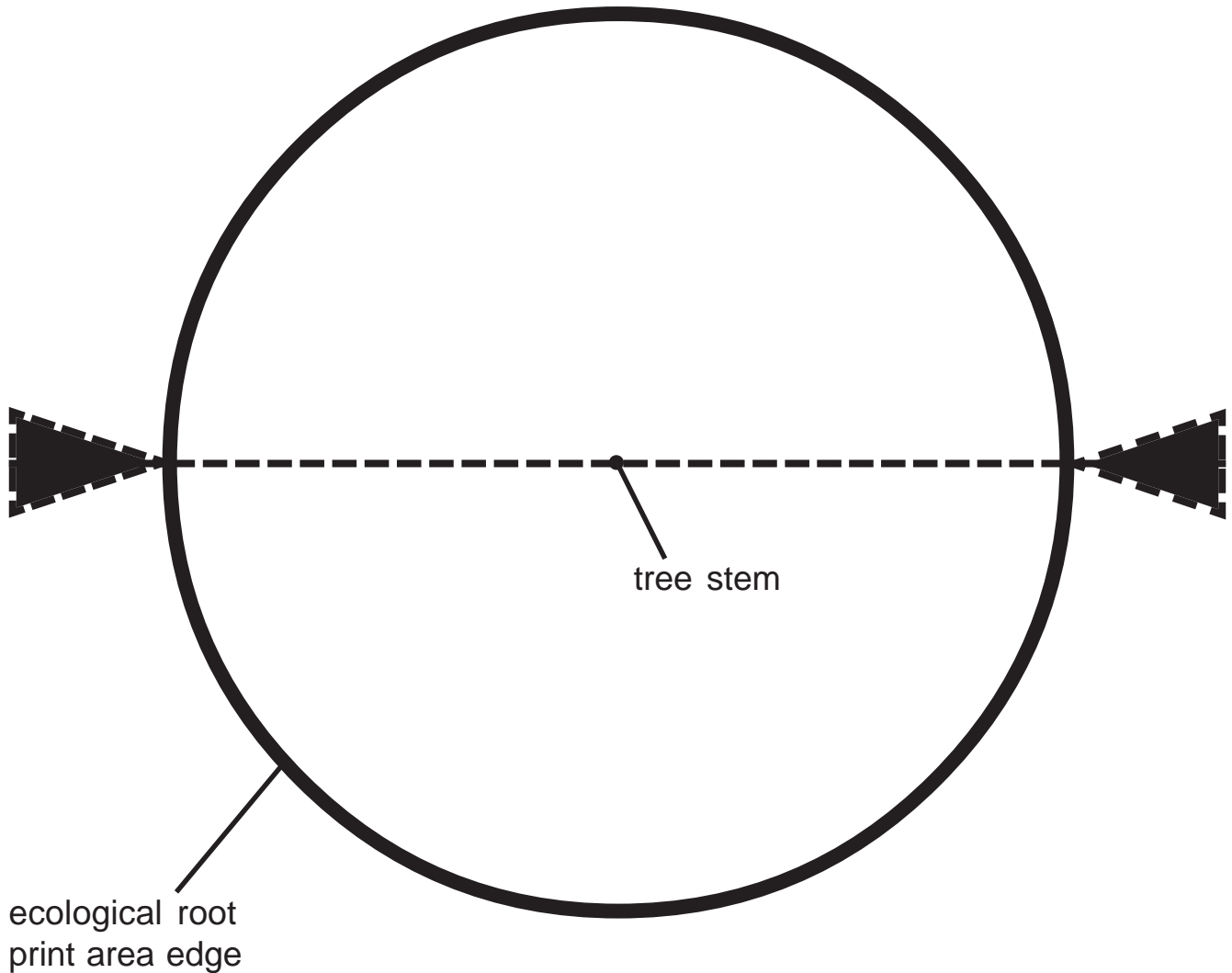

4.0 X DIAMETER OF TREE
(DBH in inches)

=

ECOLOGICAL ROOT PRINT DIAMETER (in feet)

TOOL #4: Estimate the critical rooting distance for any tree in the area.

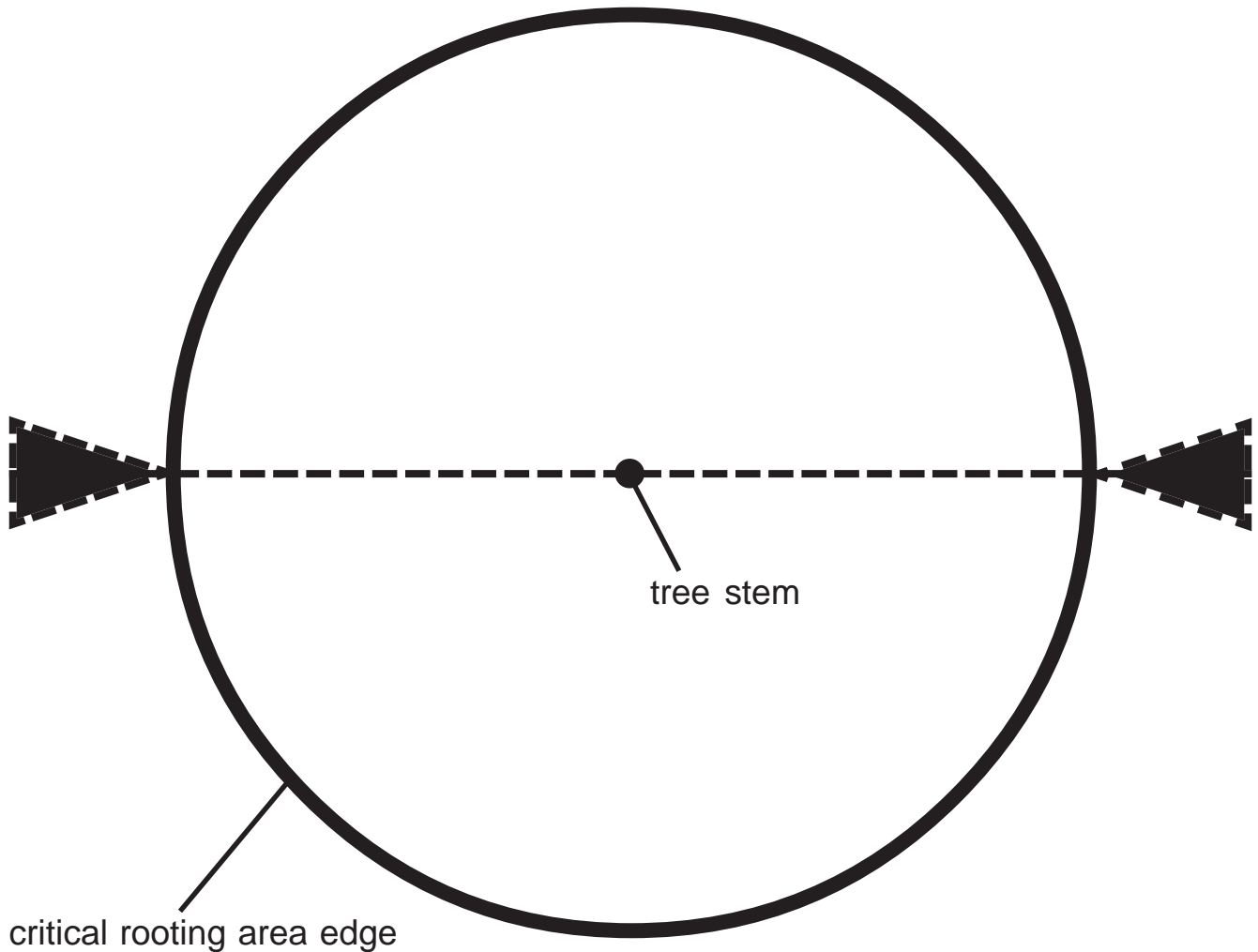

2.5 X DIAMETER OF TREE
(DBH in inches)

=

CRITICAL ROOTING AREA DIAMETER (in feet)

TOOL #5: Diagram demonstrating acceptable packing density of tree root systems, or the amount of critical rooting area overlap allowed for a tree (A) when surrounded by 2, 3, 4, or 5 other trees with, in these examples, a similar sized rooting area.

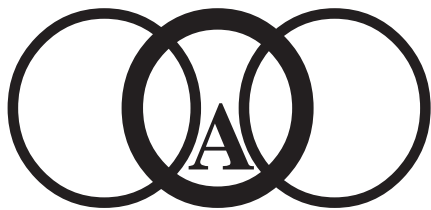

2 = 40%

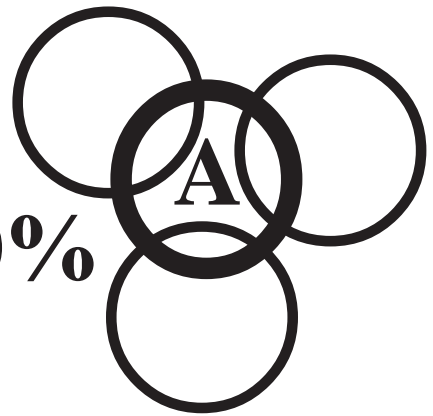

3 = 30%

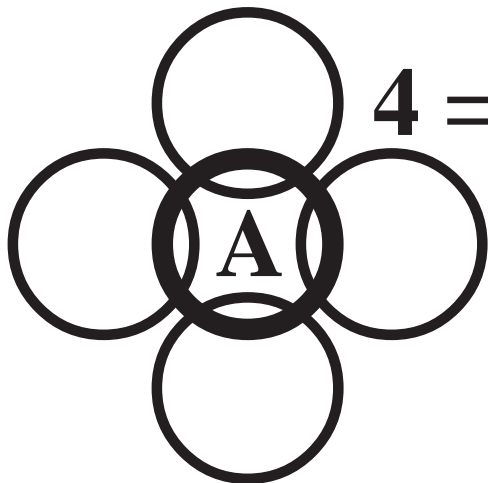

4 = 20%

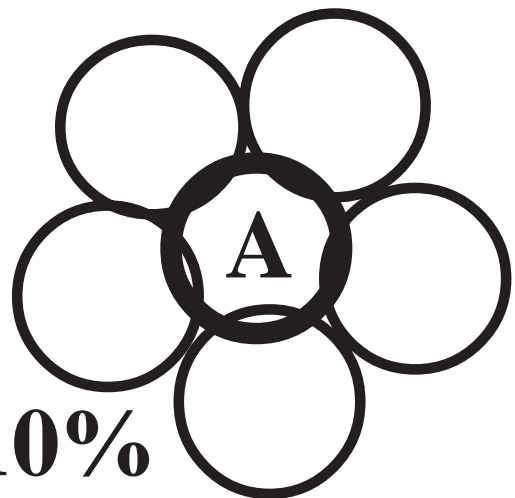

5 = 10%

6 = 0% OVERLAP

TOOL #6: Allowable joint rooting area percent or overlap of critical rooting areas.

number of trees neighboring tree A	allowed critical rooting area overlap with tree A
1	50%
2	40%
3	30%
4	20%
5	10%
>6	0%

TOOL #7: Calculated critical rooting distance radius values in feet for use in minimizing any type of encroachment on essential tree rooting space.

TREE DIAMETER (inches)	CRITICAL ROOTING DISTANCE (feet of radius)	TREE DIAMETER (inches)	CRITICAL ROOTING DISTANCE (feet of radius)
1	1.25	26	33
2	2.5	27	34
3	4	28	35
4	5	29	36
5	6	30	38
6	9		
7	9	31	39
8	10	32	40
9	11	33	41
10	13	34	43
		35	44
11	14	36	45
12	15	37	46
13	16	38	48
14	18	39	49
15	19	40	50
16	20		
17	21	45	56
18	23	50	63
19	24	55	69
20	25	60	75
		65	81
21	26	70	88
22	28	75	94
23	29	80	100
24	30	85	106
25	31	90	113

Tool #8: Percent tree rooting area disrupted when soil and roots are damaged on one side, divided into 1/5s.

rooting
area
distance

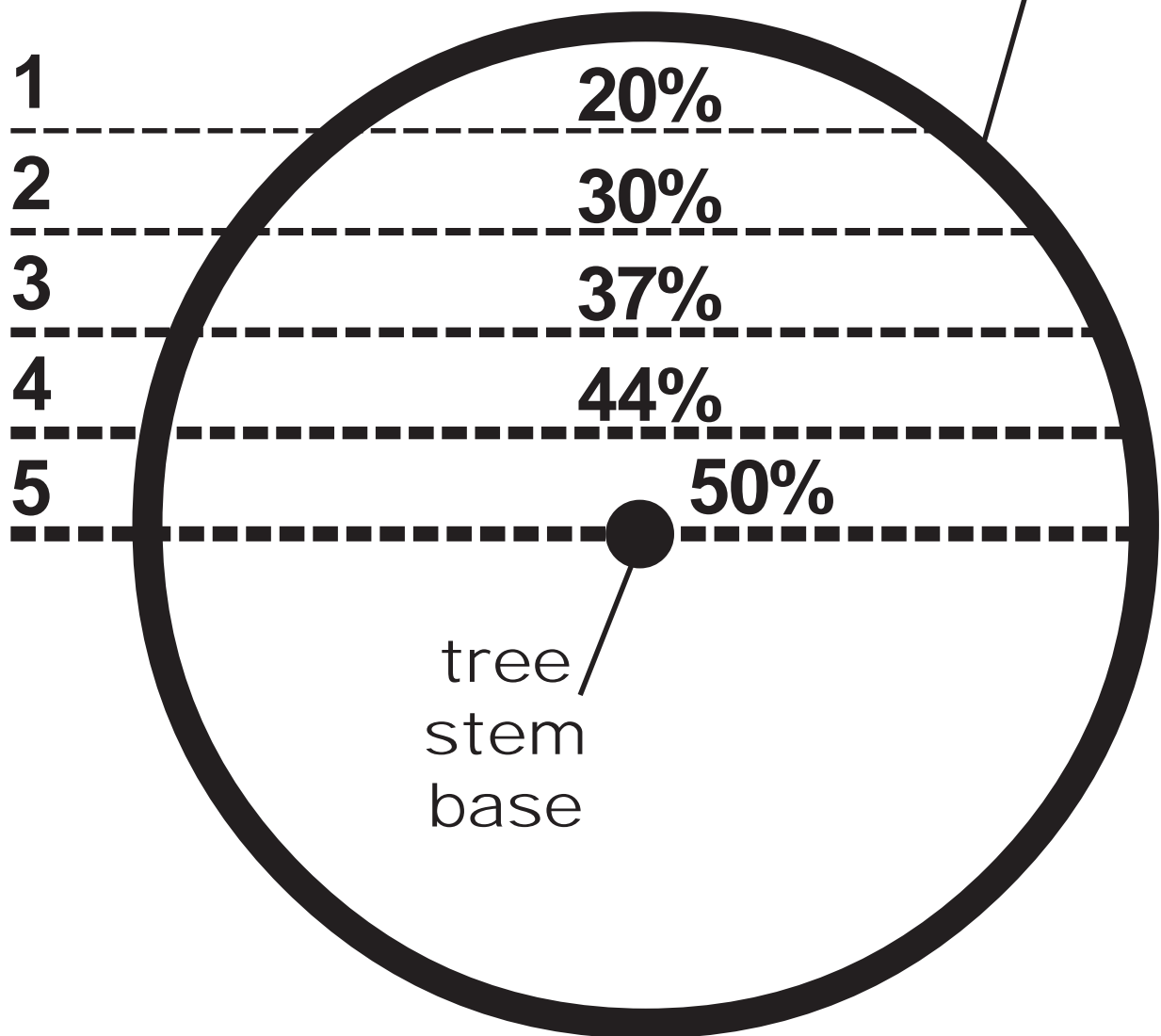

Tool #9: Percent tree rooting area disrupted when soil and roots are damaged all around a tree, divided into 1/5s.

rooting
area
distance

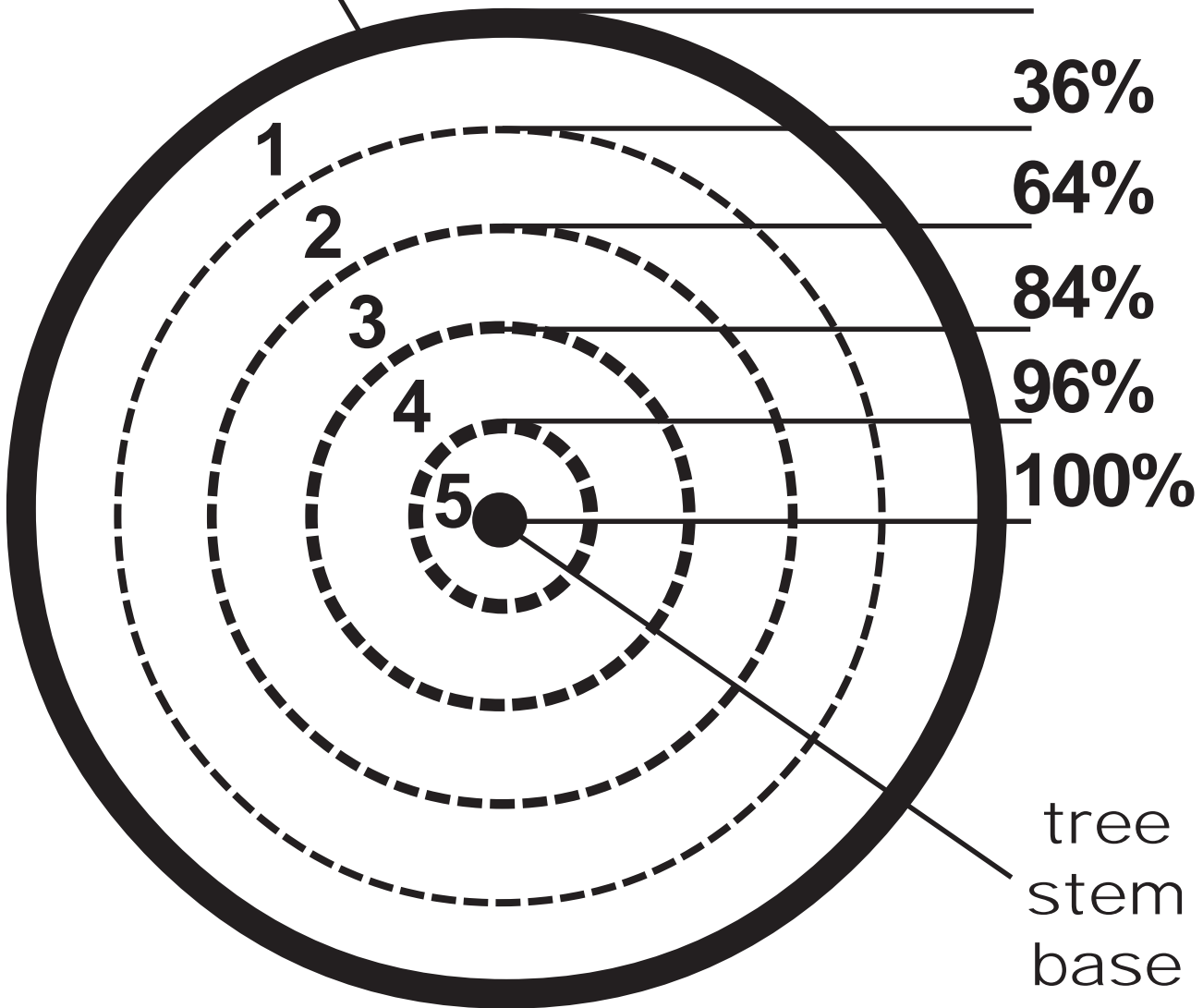

TOOL #10: Percent of critical rooting area disrupted by development activities approaching tree and impacting soil.

fifths of tree critical rooting area encroached	whole area	half area
1/5	36%	20%
2/5	64%	30%
3/5	84%	37%
4/5	96%	44%
5/5 (all soil)	100%	50%

TOOL #11: Side view of a tree root plate area showing root plate depth and location of hinge point.

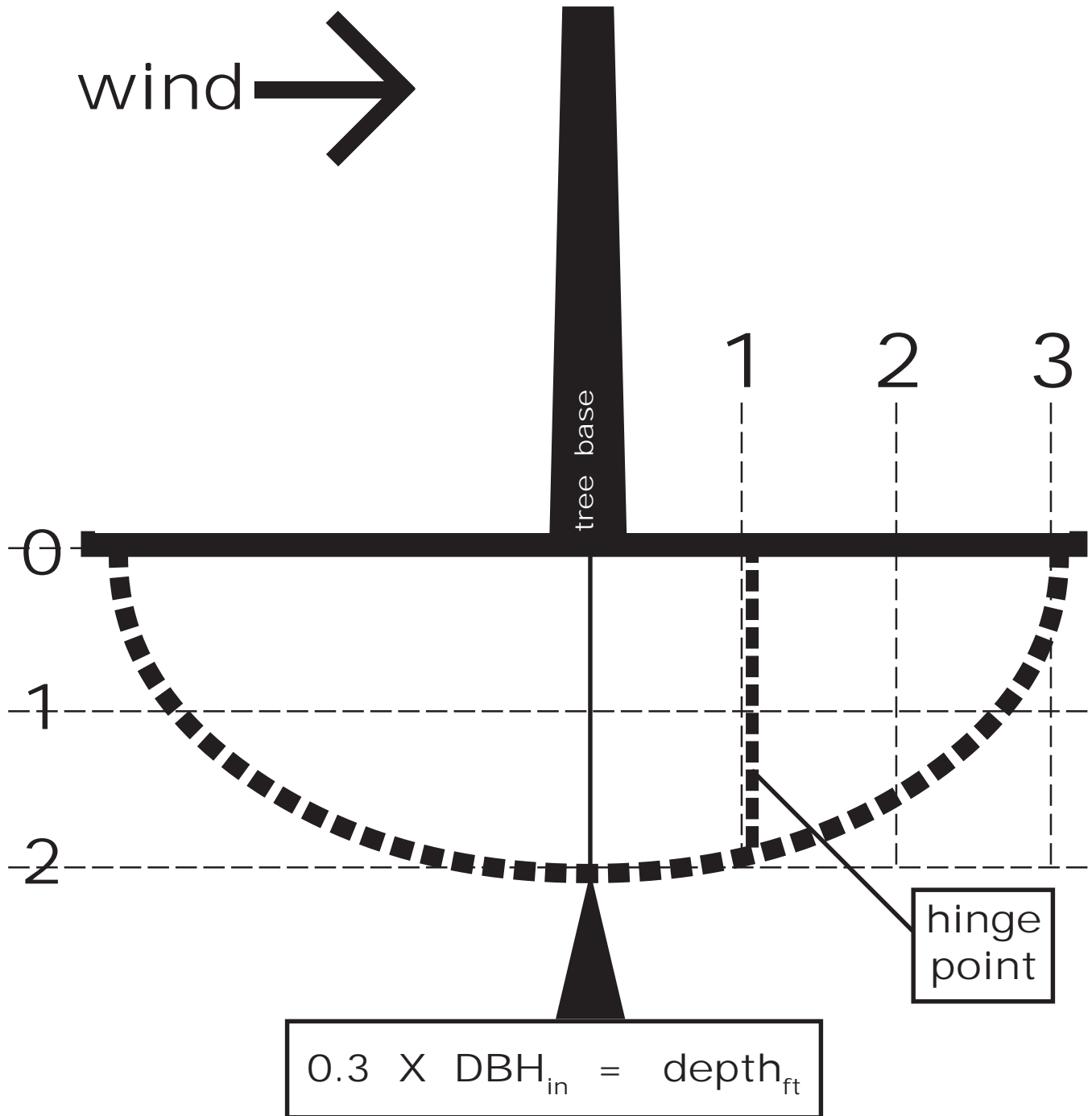

TOOL #12: View from above of a tree root plate surrounding a tree of a set diameter (DBH_{in}).

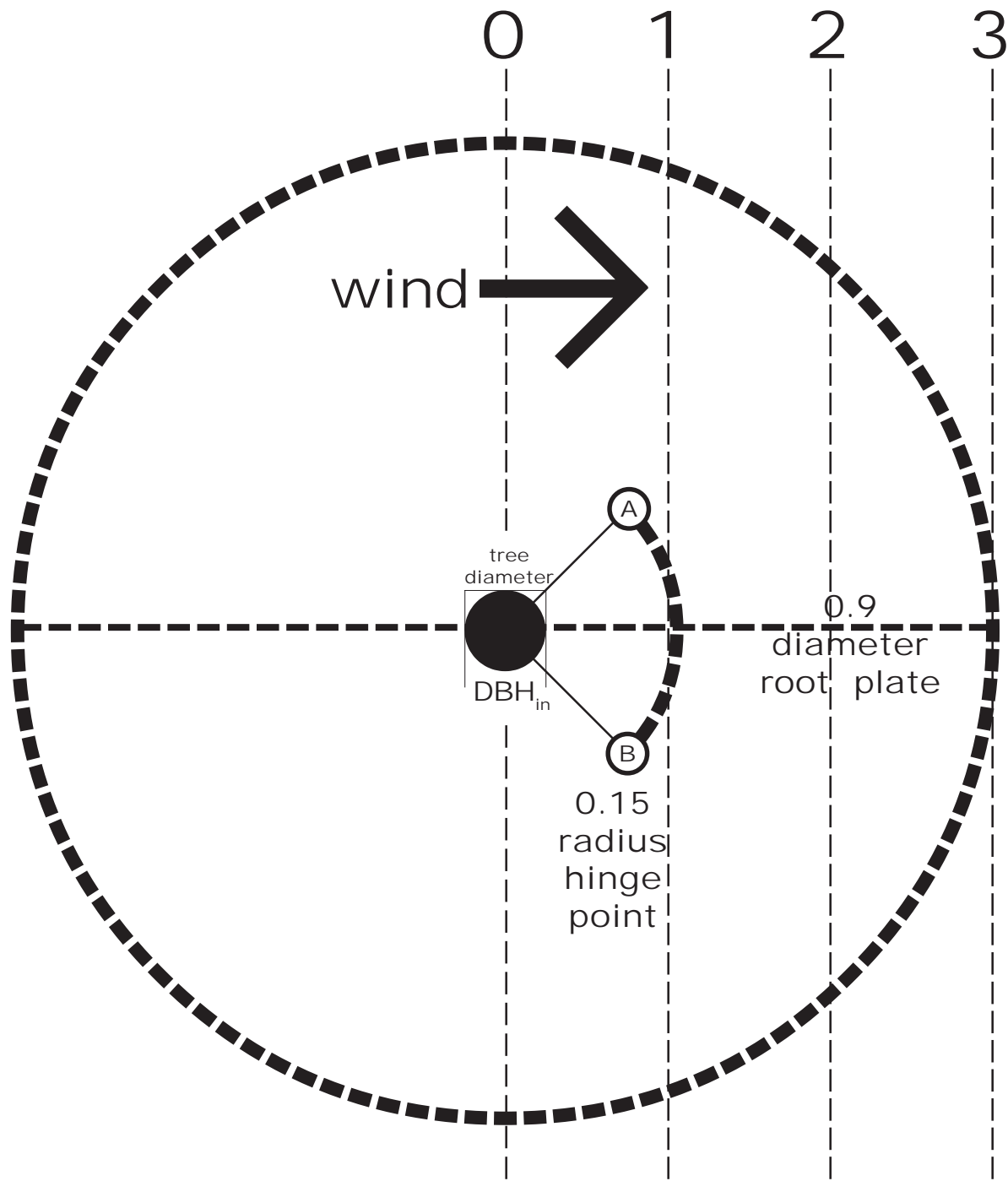

TOOL #13: Estimate the structural rooting area distance for any tree in the area.

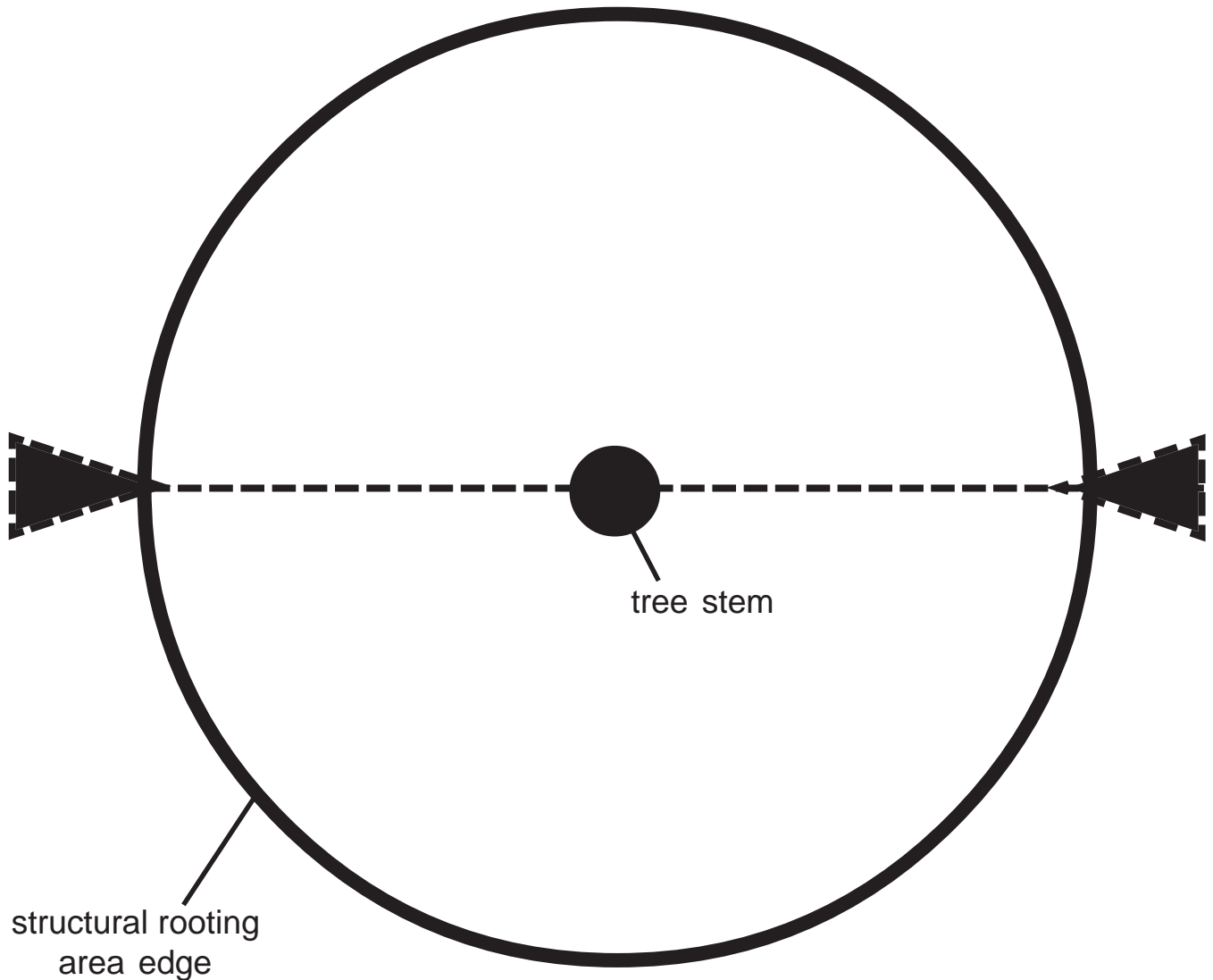

0.9 X DIAMETER OF TREE
(DBH in inches)

=

STRUCTURAL ROOTING AREA DIAMETER
(in feet)

TOOL #14: Structural rooting distance in feet of radius, or root plate radius distance, used to minimize damage to tree structural base and minimize catastrophic tree failures due to root damage.

TREE DIAMETER (inches)	STRUCTURAL ROOTING DISTANCE (feet of radius)	TREE DIAMETER (inches)	STRUCTURAL ROOTING DISTANCE (feet of radius)
1	0.5	26	12
2	1.0	27	12
3	1.5	28	13
4	2	29	13
5	2	30	14
6	3		
7	3	31	14
8	4	32	14
9	4	33	15
10	5	34	15
		35	16
11	5	36	16
12	5	37	17
13	6	38	17
14	6	39	18
15	7	40	18
16	7		
17	8	45	20
18	8	50	23
19	9	55	25
20	9	60	27
		65	29
21	10	70	32
22	10	75	34
23	10	80	36
24	11	85	38
25	11	90	41

TOOL #15: Extent and severity of mechanical injuries
to trees on development sites.

Determine & record the following items in the field —

1. Diameter of stem or branch at site of recent injury:
 - A. If the stem / branch area including the injury has little or no taper along its longitudinal axis then measure mid-injury diameter of the stem / branch. (midDIAMETER)

OR

 - B. If the stem / branch area including the injury area has significant taper along its longitudinal axis, from injury top to bottom, then measure the diameter of the stem / branch at the top and bottom of injury. (topDIAMETER & bottomDIAMETER)
2. Dimensions of the injury:
 - A. Total linear height or length (along longitudinal axis) of injury on stem / branch. (injuryHEIGHT)
 - B. Total linear width (perpendicular to longitudinal axis) of injury — not circumference of injury area. (injuryWIDTH)
 - C. Depth of injury at deepest point (as best as can be determined or estimated). (injuryDEPTH)
3. Estimate number of annual rings and tissue types breached with injury.
4. Location of injury section in tree.
5. Species of tree —
attempt to gauge effectiveness & efficiency of tree reactions to injury.

TOOL #16: Steps in determining Damage Assessment Value for a tree injury.

STEP 1A: Determine stem / branch whole segment volume (no taper) =
 $\text{injuryHEIGHT} * 0.785 * (\text{midDIAMETER})^2$

OR

STEP 1B: Determine stem / branch whole segment volume (taper) =
 $\text{injuryHEIGHT} * 0.262 * (\text{topDIAMETER})^2 +$
 $0.785 * (\text{bottomDIAMETER})^2 +$
 $\text{SQUARE ROOT} (0.616 * (\text{topDIAMETER})^2 * (\text{bottomDIAMETER})^2).$

STEP 2: Determine injury segment volume (ellipsoidal shape factor) =
 $0.5 * \text{injuryHEIGHT} * \text{injuryWIDTH} * \text{injuryDEPTH}.$

STEP 3: Determine DAMAGE EXTENT SCORE =
 $((\text{VOLUME of injury segment (STEP 2)} /$
 $\text{VOLUME of whole segment (STEP 1)}) * 100$

STEP 4: Determine DAMAGE SEVERITY SCORE.
Estimate number of annual rings & tissue types breached in injury.

Select one description that most fully matches the depth of the injury:

1. Bark to xylem (score = 0)
2. Expanded growing points, one, or two year old xylem (score = 1)
3. Three to seven year old xylem -- 100% sapwood (score = 2)
4. Seven year old xylem to end of sapwood -- 100% sapwood (score = 5)
5. Heartwood (score = 11)
6. Existing damage-modified heartwood and discoloration / decay columns (score = 23)

STEP 5: Determine DAMAGE LOCATION SCORE. (Note TOOL #17)

1. Root collar / stem base area — two feet out and four feet up (score = 7)
2. Root plate area -- structural rooting zone supporting tree under compression (score = 6)
3. Stem base of the live crown (score = 5)
4. Stem / trunk (score = 4)
5. Injury into reaction wood on basal 1/4 of the length of primary scaffold branches -- upper side tension wood in angiosperms & lower side compression wood in non-angiosperms (score = 3)
6. Ground contact / rain splash / direct irrigation wetting area (score = 2)
7. South and Southwest exposure with full sun (score = 1)

Locations numbers 1-5 above are unique positions and are non-additive. Locations numbers 6 & 7 are additive with other location scores.

STEP 6: Determine DAMAGE ASSESSMENT VALUE.

$$\begin{aligned} \text{DAMAGE ASSESSMENT VALUE} &= \\ \text{DAMAGE EXTENT SCORE} &+ \\ \text{DAMAGE SEVERITY SCORE} &+ \\ \text{DAMAGE LOCATION SCORE.} & \end{aligned}$$

Species and individual tree differences play a critical role in setting management objectives for an area and risk acceptance levels and tree removal decisions using the DAMAGE ASSESSMENT VALUE.

For long-term tree quality, suggested DAMAGE ASSESSMENT VALUES generated where managerial notice should particularly occur are at 15, 22.5, and greater than 30. Removal should be considered at a DAMAGE ASSESSMENT VALUE of 31 and above.

TOOL #17: Score values for different injury locations within critical tree structural zones for use in assessing damage.

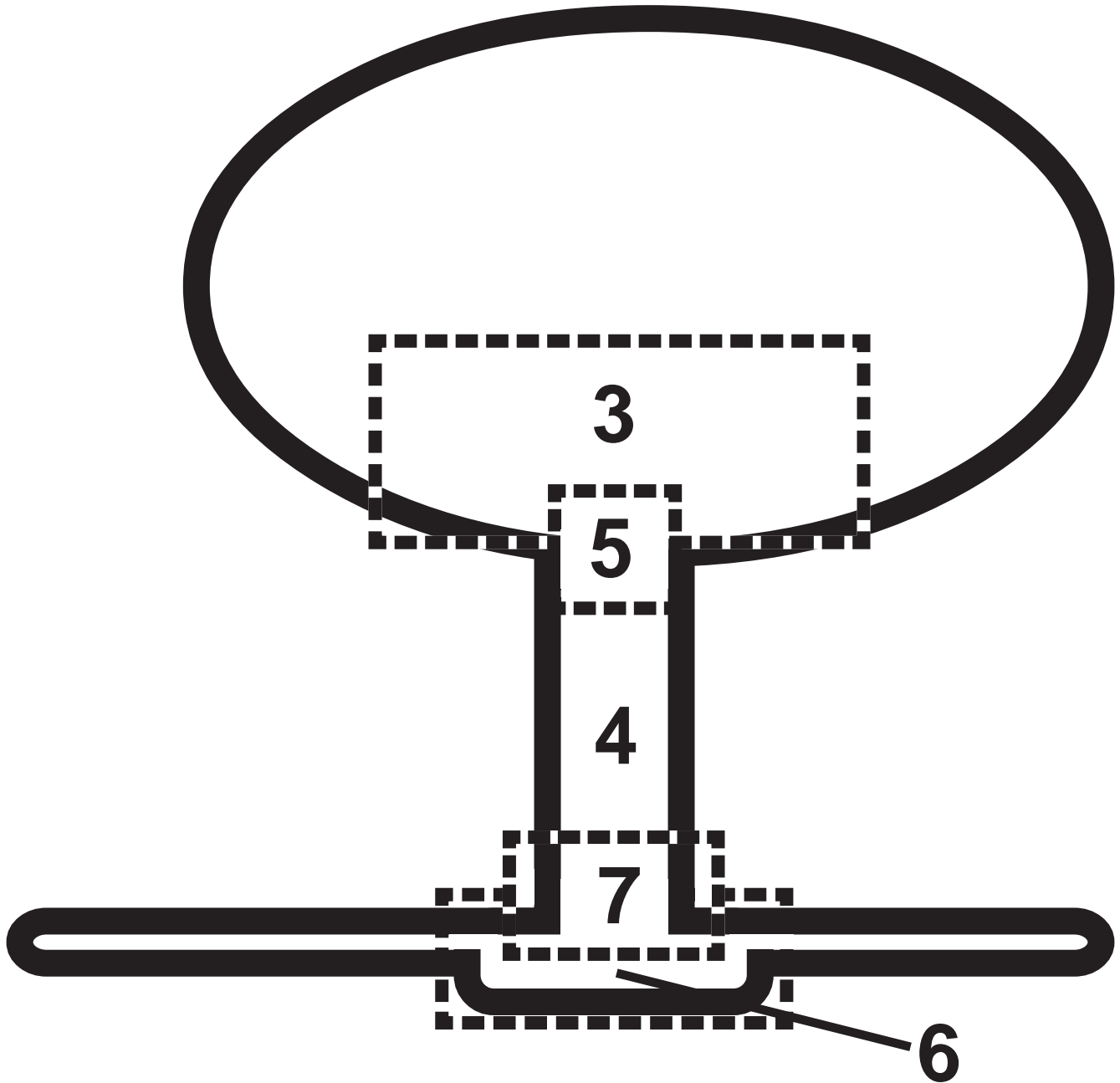

TOOL #18: Coder Crown Raising Dose Assessment per pruning cycle for demonstrating potential crown raising abuse around a development site. Graph is the percent of live crown (height basis) that can be removed, if warranted.

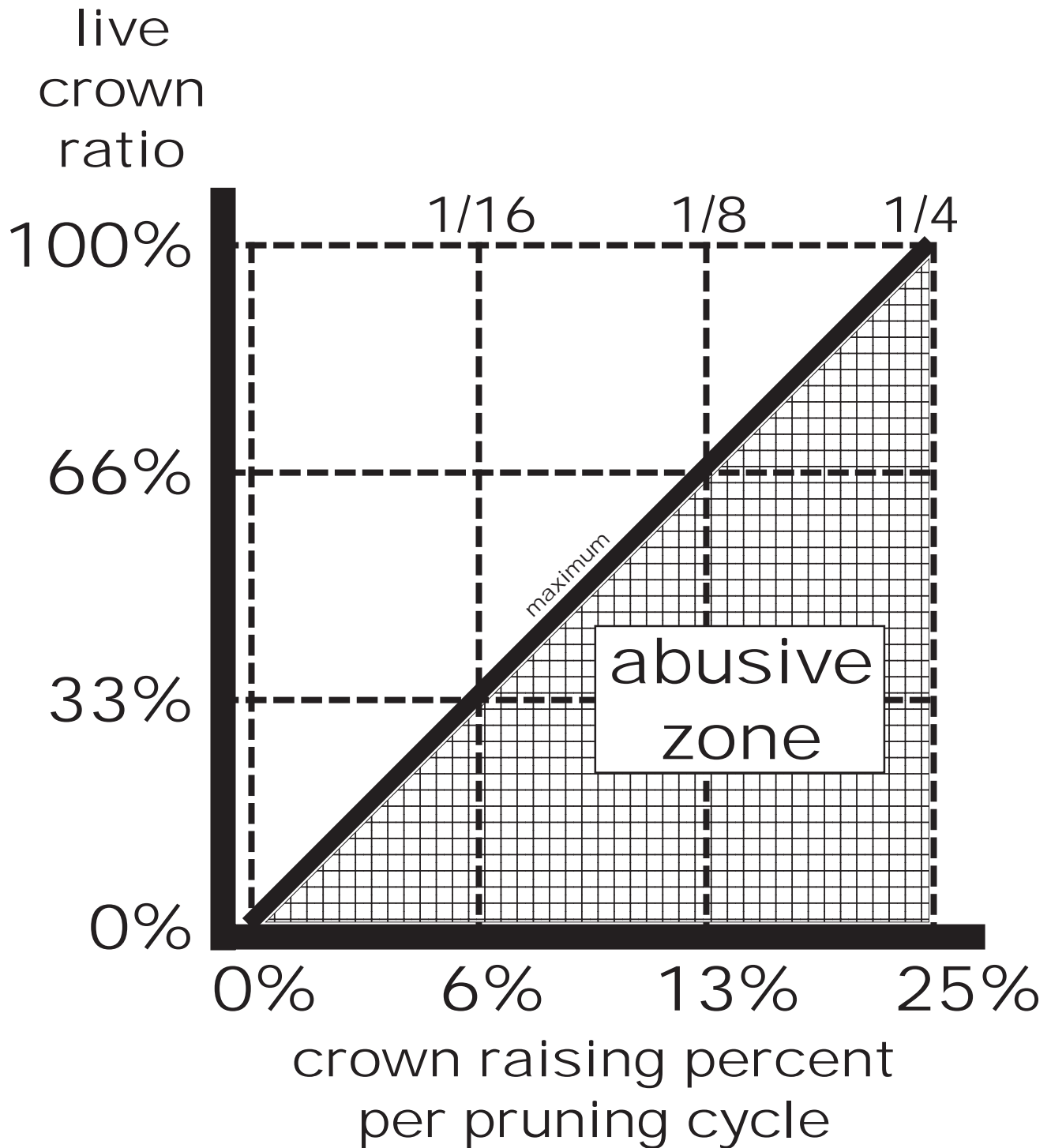

TOOL #19: Diagram of a tree stem cross-section showing sapwood and heartwood (shaded).

sapwood

heartwood

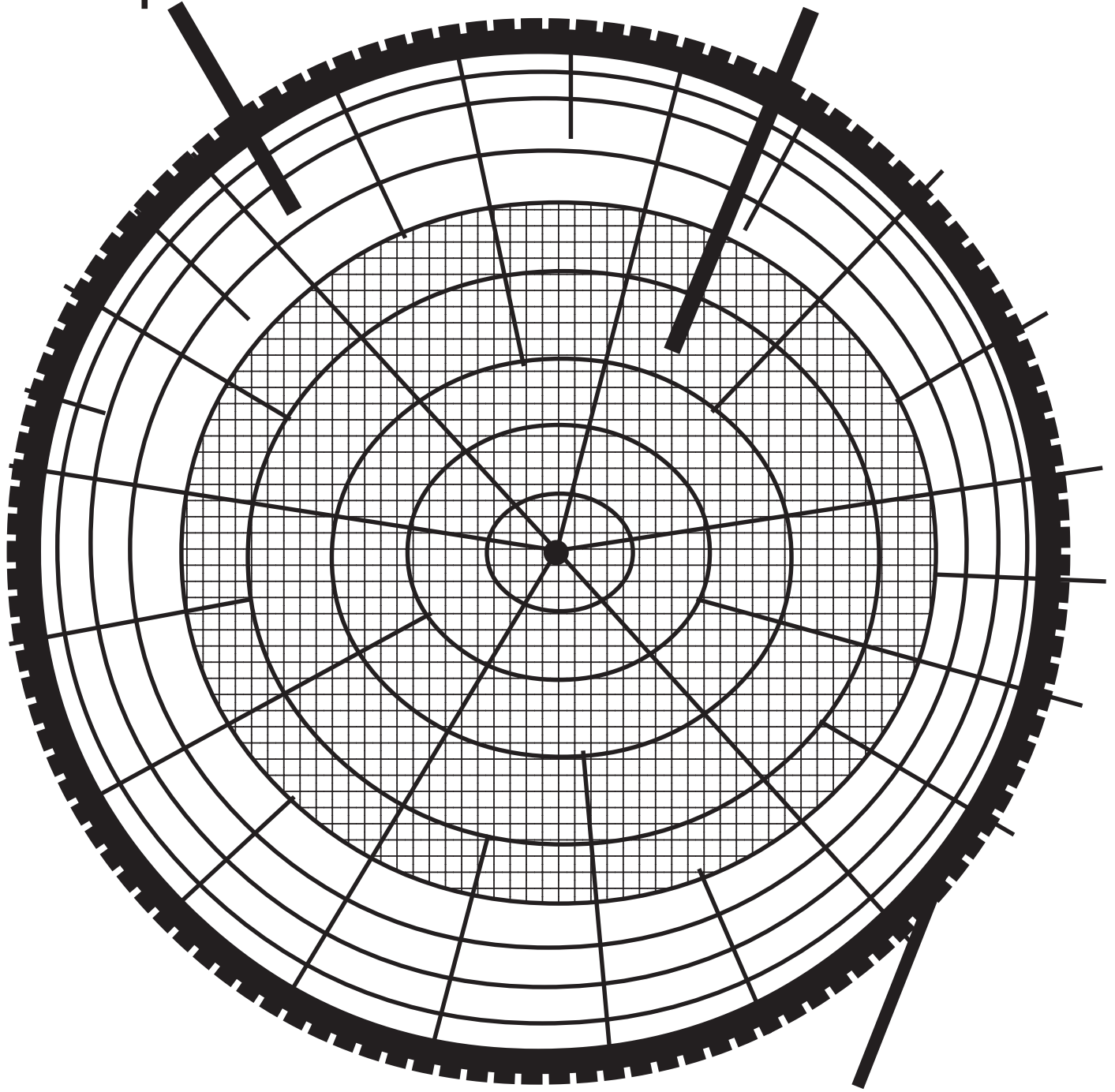

periderm

TOOL #20: Coder Heartwood Exposure on Pruning Wounds Assessment for trees pruned, tipped or topped during development.



MASSIVE
crossing already developed decay & discolored boundaries

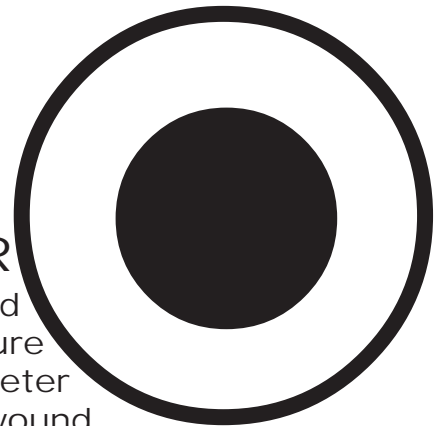

MAJOR
heartwood exposure >1/4 diameter of wound

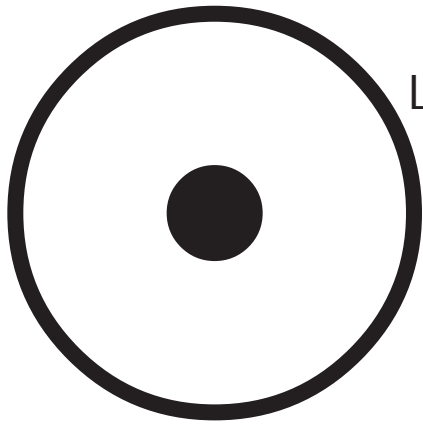

LARGE
heartwood exposure <1/4 diameter of wound



STANDARD
100% sapwood exposure

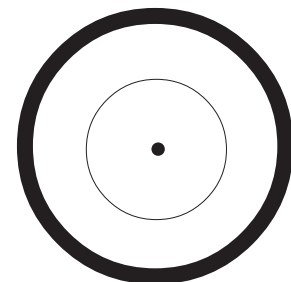
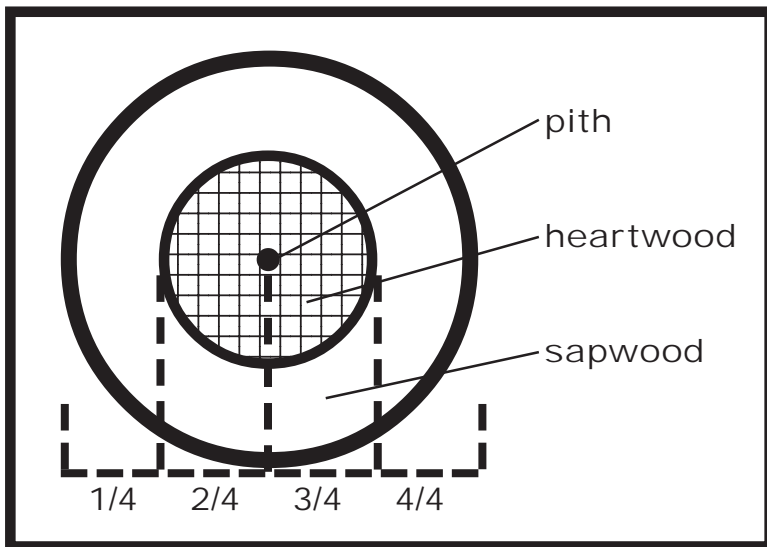

MINOR
sapwood exposure across last 2 annual increments & point bark penetrations

TOOL #21: Maximum number of pruning wounds applied to a single tree by wound type on a development site. Exceeding this count magnifies tree damage significantly.

pruning wound type	maximum number of pruning wounds to single tree
massive	1
major	3
large	7
standard	15
minor	31

TOOL #22: The number of passes over the same square inch of soil to increase bulk density (compact soil) to 95% of what it can be compacted.

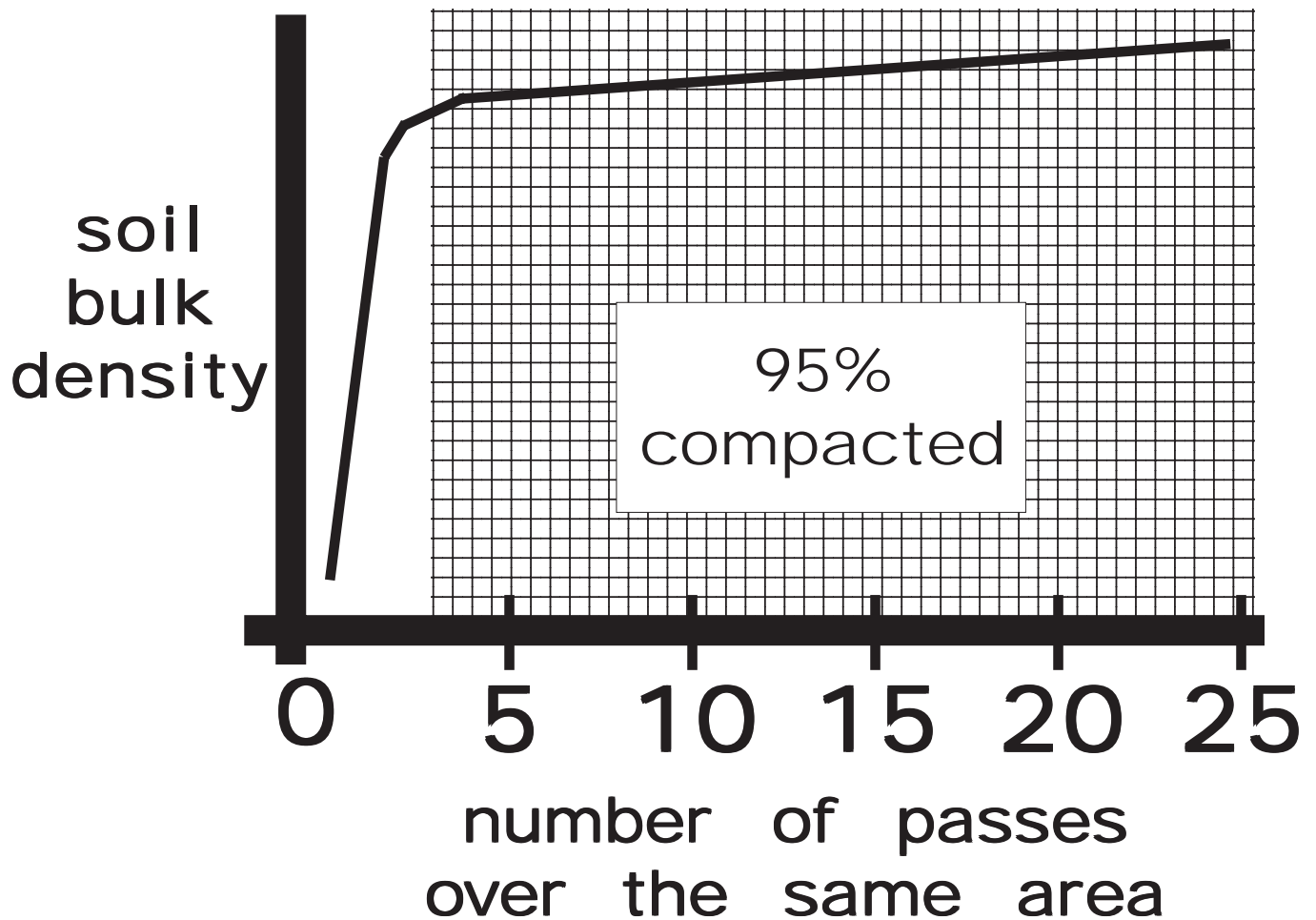

TOOL #23: Soil textures classifications based upon sand and clay proportions, and dotted lines showing root-limiting bulk densities (g/cc). Values equal to or greater than the listed density value (to the right of) will significantly constrain tree root growth.

CLAY % IN SOIL

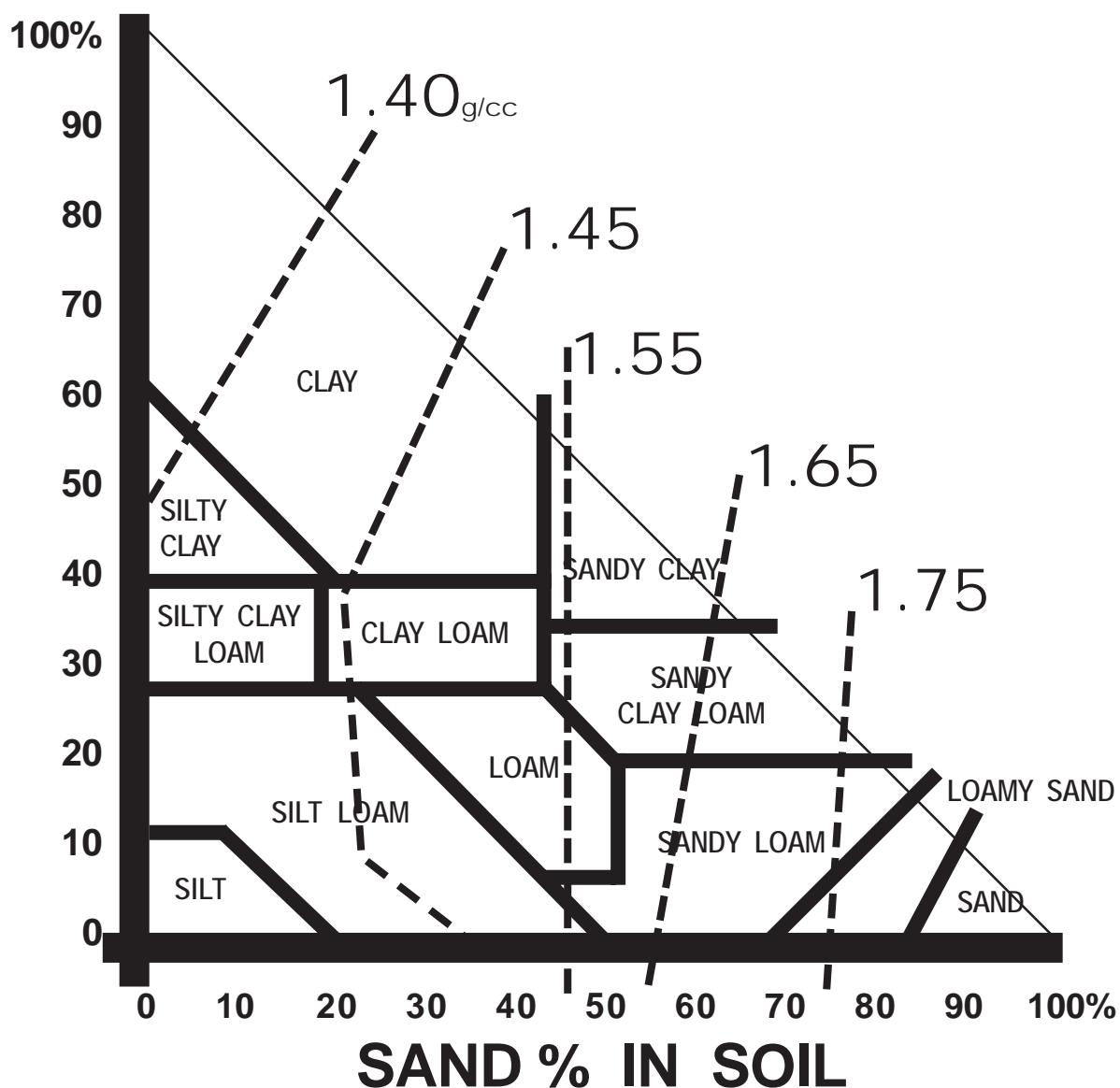

TOOL #24: Soil compaction limitations on tree root growth and survival. Listed are soil physical attributes (soil bulk density in g/cc and soil air pore space percent) by soil texture class, where tree root growth becomes severely limiting.

soil texture	root-limiting bulk density (g/cc)	root-limiting % pores normally filled with air
sand	1.8 g/cc	24 %
fine sand	1.75	21
sandy loam	1.7	19
fine sandy loam	1.65	15
loam	1.55	14
silt loam	1.45	17
clay loam	1.5	11
clay	1.4	13

TOOL #25: Effective soil depth in soils of various textures under compacted and non-compacted conditions.

soil depth
inches
(feet)

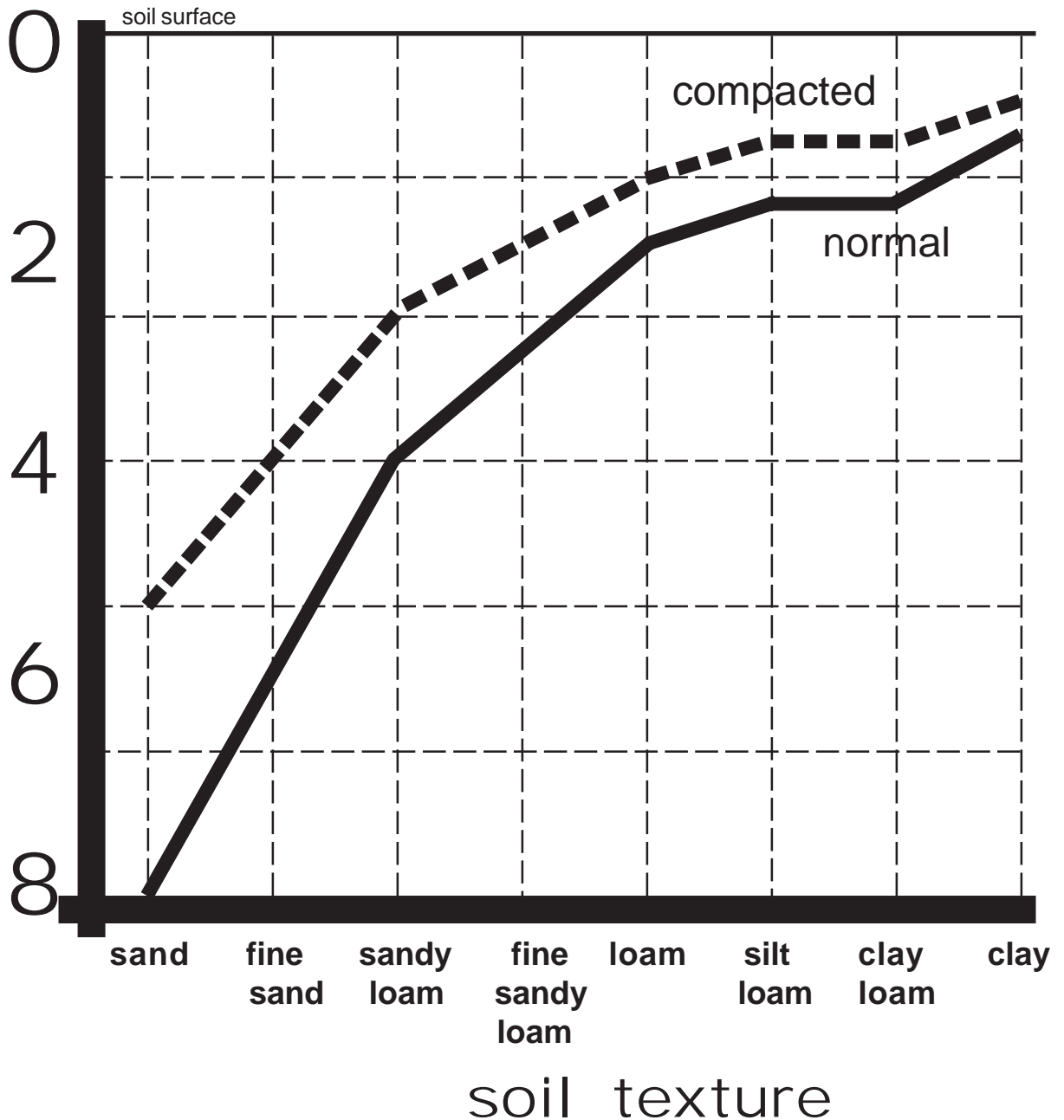

TOOL 26: Soil rutting potential on wet soils under development activities. Ground pressure (psi) for vehicles: rubber tires = 20+; crawler track = 12+; and, floatation tires = 6+.

Ground Pressure (psi)

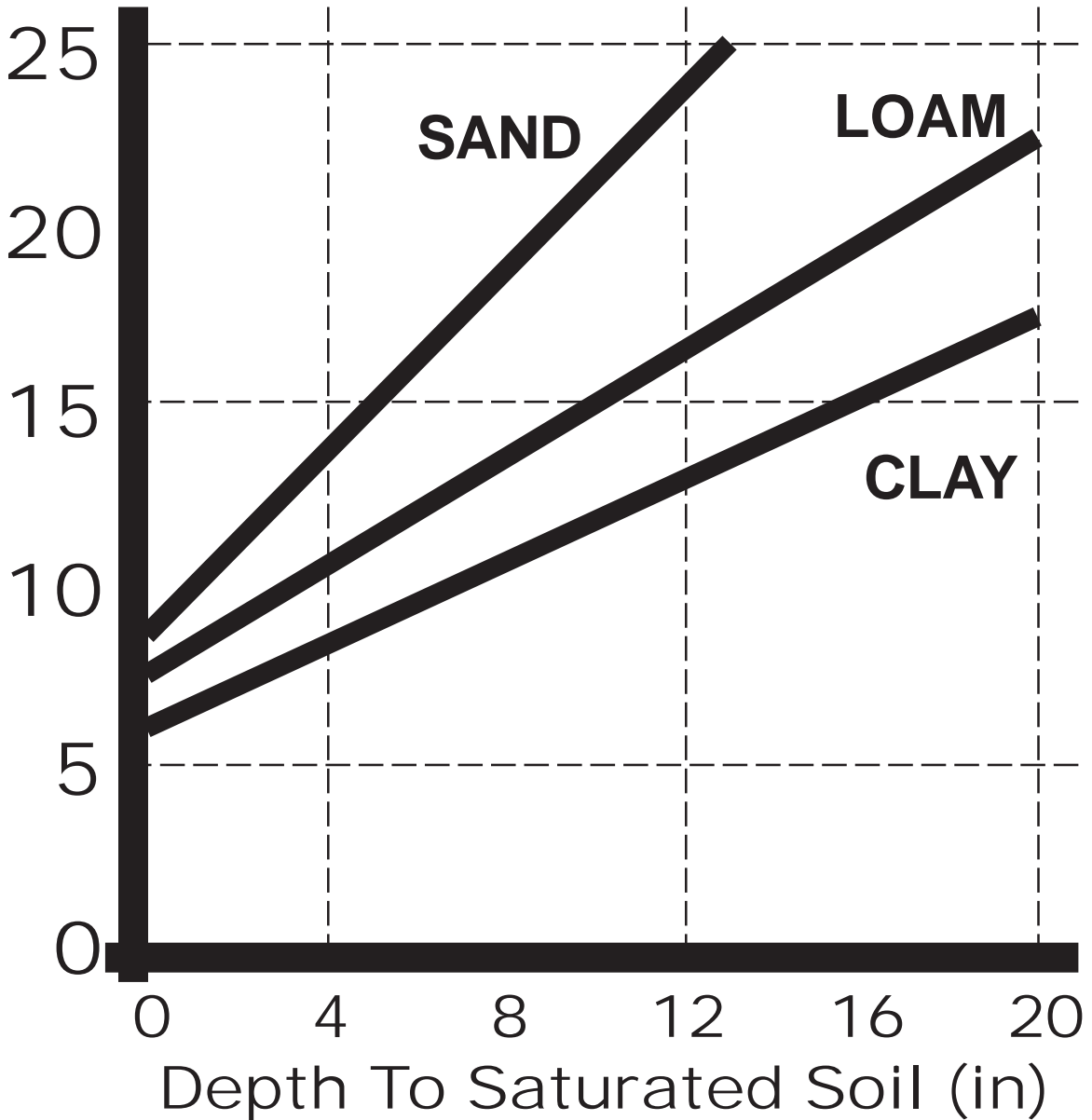

TOOL #27: Soil fill or lifts.

soil texture	initiation of root damaging soil fill	massive root damaging soil fill
sand	8 inches	24 inches
fine sand	6	18
sandy loam	4	12
fine sandy loam	3	9
loam	2	6
silt loam	1.5	4.5
clay loam	1.5	4.5
clay	1	3

TOOL #28: Soil cuts.

soil texture	significant root damaging soil removals
sand	10 inches
fine sand	8.5
sandy loam	7
fine sandy loam	5.5
loam	4
silt loam	3
clay loam	3
clay	2

TOOL #29: Tree Structural Risk Assessment.

ZONE 1: STEM / ROOT BASE (4 feet up and out) -- Bottom four feet of main stem and zone of rapid taper (ZRT) in roots stretching out four feet.

NO COMPROMISE -- NO DOUBT

ZONE 2: MAIN STEM (up to live crown and base of scaffold branches)

ZONE 3: PRIMARY ROOT SUPPORT (out to 1/2 drip line)

ZONE 4: PRIMARY BRANCH SUPPORT (major branch base area plus basal 1/3 of their length) Faults in zones two, three, and four are correctable with large inputs of time, money, materials and technical maintenance.

Corrective measures may represent a notification of problems.

ZONE 5: REMAINDER OF WOODY ROOTS (out to 1.5 times dripline)

ZONE 6: REMAINDER OF CROWN

Zones five and six are not of primary structural concern but any faults still represent significant risks

Criteria: When three significant simple faults potentially leading to catastrophic loss are identified (in zone order), or one significant compound fault potentially leading to catastrophic loss is identified, stop and assess targeting aspects of the area, and reexamine site management objectives to determine risk designation (and removal priority if warranted). Examine tree from at least three sides.

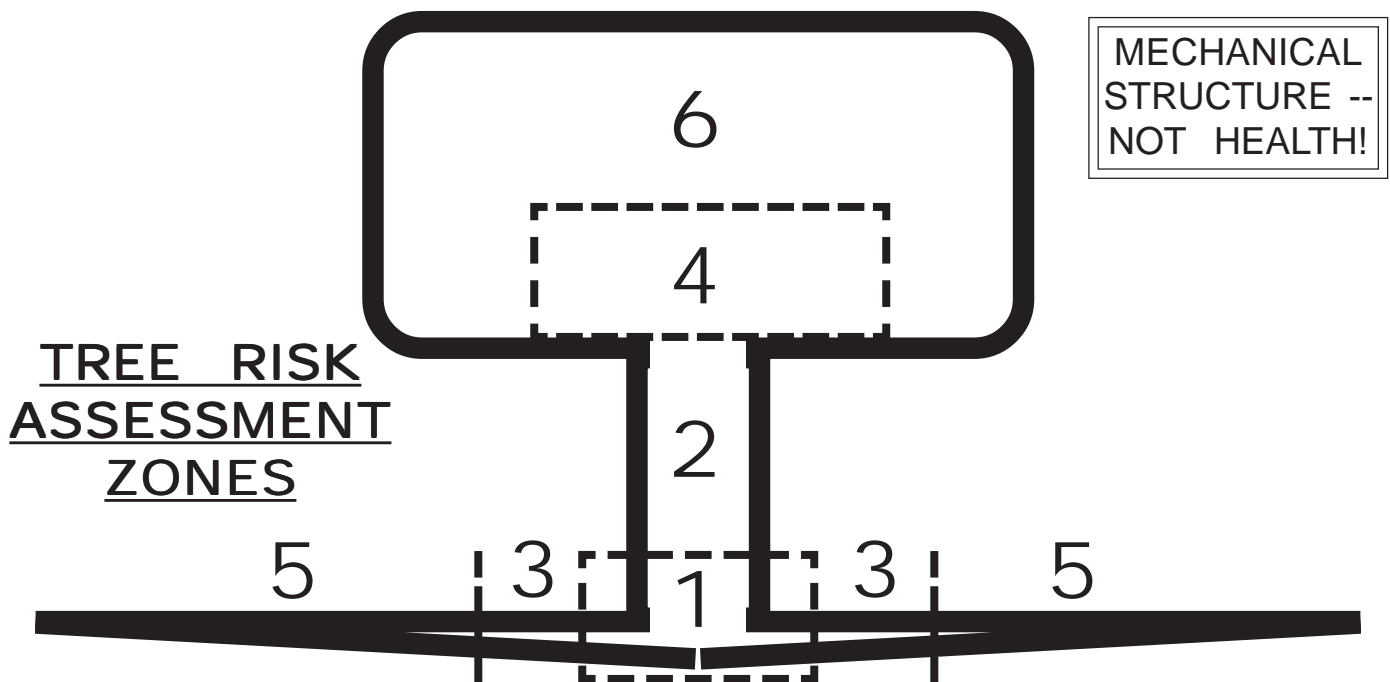

TOOL #30: Tree Structural Risk Assessment Form.

TREE NUMBER:
ASSESSOR'S NAME:

DATE:

TREE SPECIES:
SPECIFIC TREE LOCATION:

TREE DIAMETER:

OWNERSHIP:

BOUNDARY LINE TREE _____
OWNER'S NAME(S):

SINGLE OWNER TREE _____
PHONE(S):

TREE HEIGHT:

DISTANCE FROM OTHER OWNERSHIP:

RISK ASSESSMENT:

MAJOR STRUCTURAL FAULTS (describe type and location):

FAULT #1 (ZONE=): _____

FAULT #2 (ZONE=): _____

FAULT #3 (ZONE=): _____

OTHER STRUCTURAL FAULTS:

MINOR RISKS:

TARGETING (people / property / resources over space and time):

RISK ACCEPTANCE BY OWNER GIVEN MANAGEMENT OBJECTIVES:
(hazard threshold)

ACTIONS RECOMMENDED: (ALWAYS MANAGERIAL / OWNER NOTICE OF RISKS)

_____ NO REMOVAL / NO RISK REDUCTION ACTION

_____ CORRECTIONS OF MINOR FAULTS / RISK REDUCTION

_____ REMOVAL

TOOL #31: Diagram showing how heat loading can be estimated on a site using a combined and averaged view-factor from 10 equal (36°) observation angles.

(distances given above are based upon an observation height of 5.5 feet)

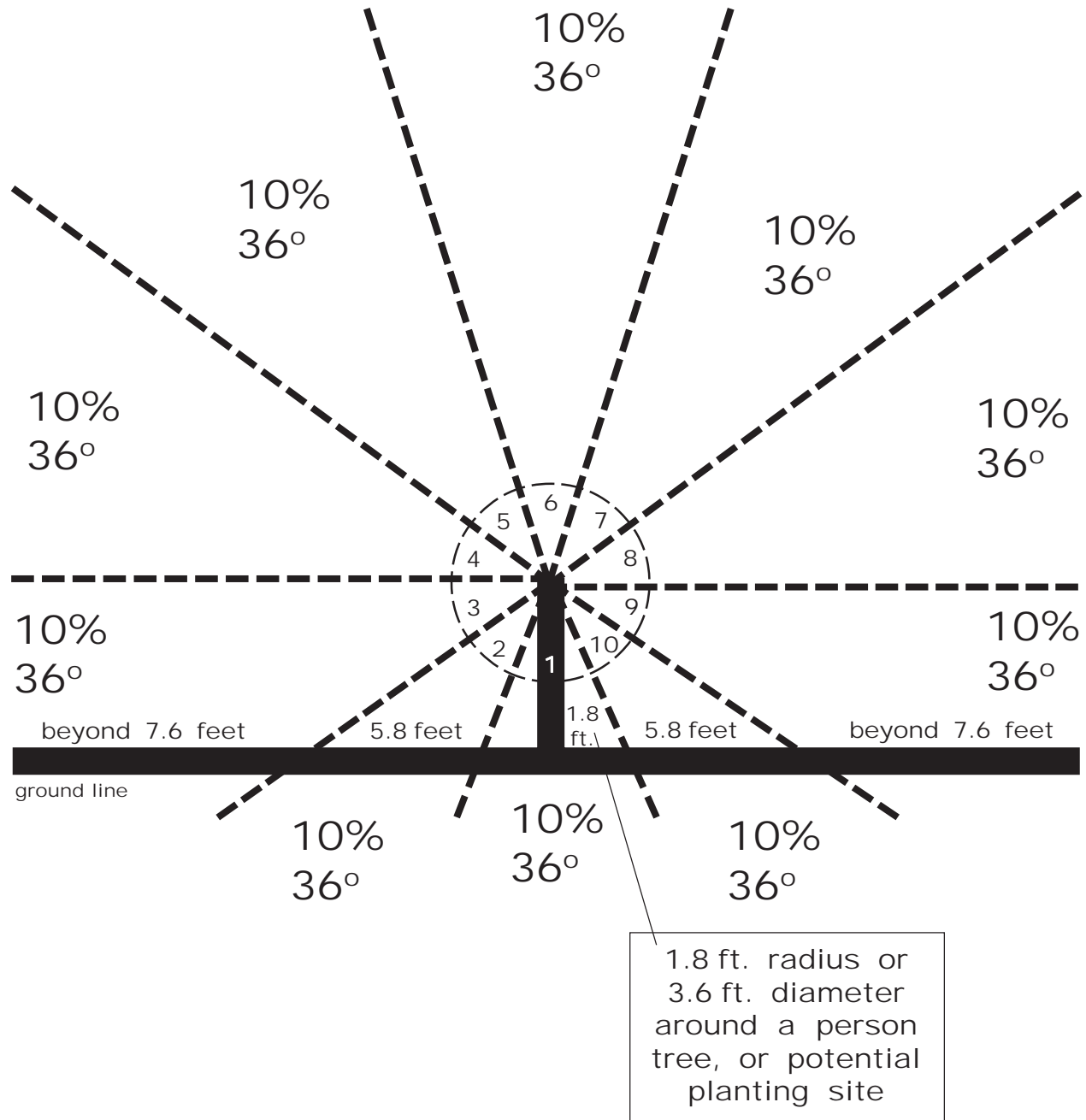

TOOL #32: Heat load multiplier values for various non-evaporative, dense surface view-factors (nearest 10% class) for a site or tree. Use heat load multiplier to estimate increased water use and carbohydrate use in trees under various heat loads.

view-factor percent of non-evaporative, dense surfaces facing site	heat load multiplier
100%	3.0
90%	2.7
80%	2.4
70%	2.1
60%	1.9
50%	1.7
40%	1.5
30%	1.3
20%	1.2
10%	1.1
0%	1.0

TOOL #33: Tree Growth Season Damage Exposure.

Four Tree Growth Periods			
YEAR #1: dormancy DORM	first portion of growing season GS1	second portion of growing season GS2	senescence SENC
YEAR #2: dormancy DORM	first portion of growing season GS1	second portion of growing season GS2	senescence SENC
YEAR #3: dormancy DORM	first portion of growing season GS1	second portion of growing season GS2	senescence SENC
YEAR #4:	--(etc.)--		

TOOL #34: Calculation of Tree Damage Exposure Value

$$\begin{aligned} \text{TREE DAMAGE EXPOSURE VALUE} = & \\ & (\text{SEASONS INFLUENCED NUMBER} + \\ & \text{SEASONAL STARTING PENALTY NUMBER} + \\ & \text{SEASONAL ENDING PENALTY NUMBER}) \times \\ & \text{MULTIPLE-YEAR PENALTY FACTOR.} \end{aligned}$$

TREE DAMAGE EXPOSURE VALUE COMPONENTS

1) SEASONS INFLUENCED

(tree growth periods impacted by site development activities)

full year (GS1 + GS2 + SENC + DORM) = 25

dormant season (DORM) = 1

full growing season (GS1 + GS2 + SENC) = 24

first portion growing season (GS1) = 12

second portion growing season (GS2) = 9

senescence season (SENC) = 3

2) SEASONAL STARTING PENALTY

(tree growth period when construction began)

dormant season (DORM) = 0

first portion growing season (GS1) = 6

second portion growing season (GS2) = 4

senescence season (SENC) = 2

3) SEASONAL ENDING PENALTY

(tree growth period when construction ended)

dormant season (DORM) = 0

first portion growing season (GS1) = 6

second portion growing season (GS2) = 0

senescence season (SENC) = 0

4) MULTIPLE-YEAR PENALTY (number of dormant period lay-overs)

-- multiply the summed results of preceding three steps by (1.05^{years})

examples: 2 years = $1.05^2 = 1.10X$; 3 years = $1.05^3 = 1.16X$.

5) YOU HAVE NOW COMPLETED THE FOLLOWING FORMULA:

TREE DAMAGE EXPOSURE VALUE =

(SEASONS INFLUENCED NUMBER +
SEASONAL STARTING PENALTY NUMBER +
SEASONAL ENDING PENALTY NUMBER) X
MULTIPLE-YEAR PENALTY FACTOR.

TOOL #35: Calculated Tree Damage Exposure Values

<u>ACTIVITIES END</u>	<u>ACTIVITIES BEGIN</u>			
	YEAR 1 DORM	YEAR 1 GS1	YEAR 1 GS2	YEAR 1 SENC
YEAR 1 DORM	1	---	---	---
YEAR 1 GS1	18	24	---	---
YEAR 1 GS2	22	27	13	---
YEAR 1 SENC	25	30	16	5
YEAR 2 DORM	29	34	19	7
YEAR 2 GS1	48	54	39	26
YEAR 2 GS2	52	57	42	30
YEAR 2 SENC	55	61	45	33
YEAR 3 DORM	59	65	60	36
YEAR 3 GS1	80	86	70	57
YEAR 3 GS2	84	89	73	60
YEAR 3 SENC	87	93	77	64

TOOL #36: Tree Recovery Times based upon each tree growth period impacted by site development activities (running concurrently).

Minimum recovery times.

- Dormant season (DORM) = 1 year
- Senescence season (SENC) = 2 years
- Second portion of growing season (GS2) =
3 years plus time to
end of growing season
- First portion of growing season (GS1)
 - diffuse porous trees =
3 years plus time to
end of growing season
 - ring porous & gymnosperm trees =
4 years plus time to
end of growing season

TOOL #37: Site development and construction damage event horizon for trees.

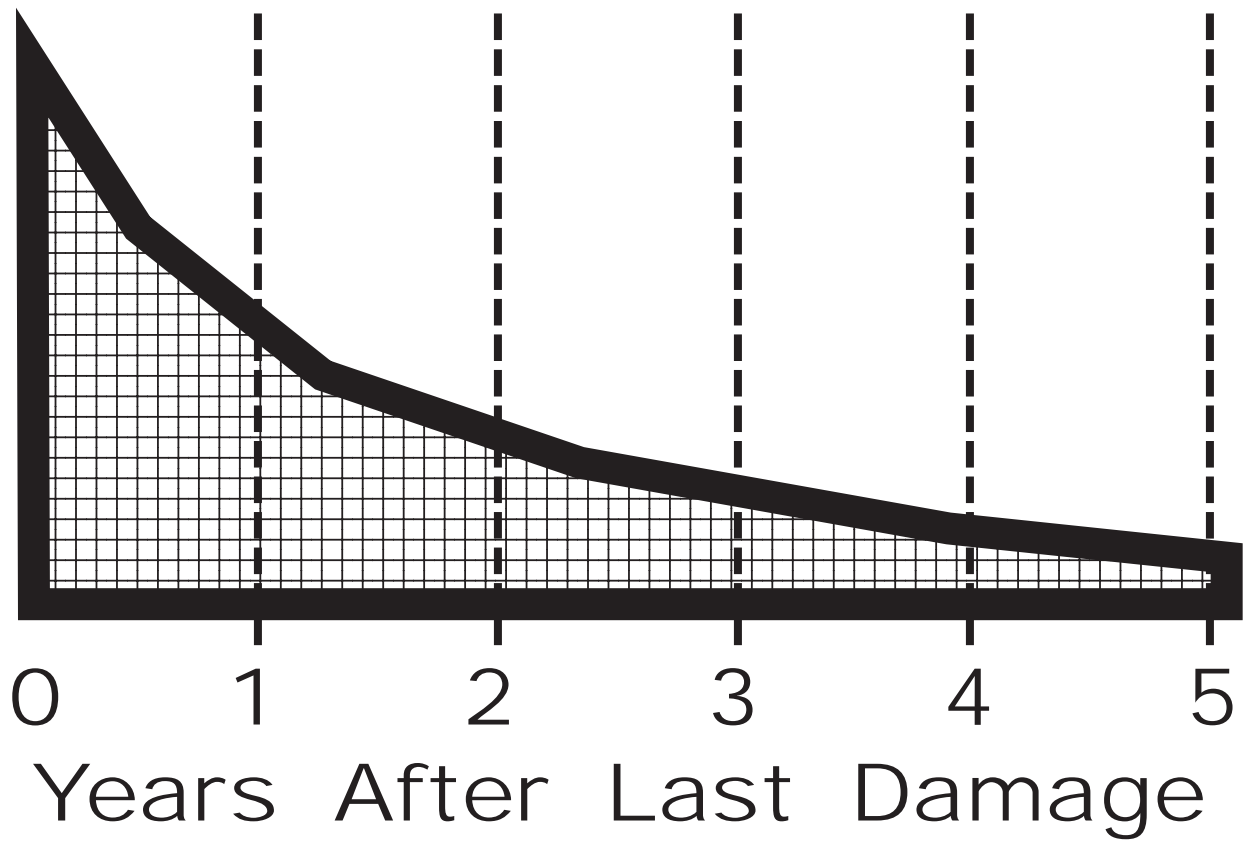

TOOL #38: Trees & Site Development Best Management Practices (BMPs) Checklist

- 1) Know the site development and building regulations concerning trees in your area.**
- 2) Establish fenced tree protection areas. For trees in harm's way, use tree protection barriers, wraps, and pads, keeping them in good repair.**
- 3) Include contractual penalties in real dollars for tree protection area violations and tree barrier damage. Allow dollars to educate reluctant or tree-illiterate people and companies.**
- 4) Plan for a cement wash-out pit and designate a chemical holding area, both away from tree protection areas.**
- 5) Limit site parking and material storage to already damaged areas.**
- 6) Allow no site-offices, equipment, or material storage in tree protection areas.**
- 7) Keep refueling and maintenance areas away from trees and native soils.**
- 8) Control toilet, lunch, break and burn areas, and associated refuse.**
- 9) Control and limit on-site soil storage.**
- 10) Control and minimize grade changes, and prevent significant water and soil flow / accumulation changes on-site across tree protection areas.**
- 11) Allow only two construction access drives into the site -- one in, one out.**
- 12) Control utility over-head and under-ground corridors.**
- 13) Be careful of fire dangers to site and surrounding woods, both during construction and afterwards.**

tree number:

damage class(es) -- describe damage

_____ Class 1 -- General root system destruction & rooting space loss:

_____ Class 2 -- Root collar and structural support root damage:

_____ Class 3 -- Mechanical / structural damage to stem and/or major branches:

_____ Class 4 -- Soil problems:

_____ Class 5 -- Wind load changes:

_____ Class 6 -- Potential obstructions:

Tree Damage Exposure Value: _____ Recovery Time: _____ years

recommendations

PRIORITY removal: _____ removal: _____ do not remove: _____

immediate treatments:

future treatments:

potential storm damage risk 1° -- 2° -- 3°
managerial notice points:

pre-construction appraised value (\$):

post-construction appraised value (\$):

expected life-span and prognosis: